

System Description: Data Entry Card

The basic programmer consists of two stackable 6.5 X 9 inch cards. The data entry system allows complete manual control and two hex digit display of data from either the data entry latches or from the copy socket. Data is entered from the Hex Keypad for initial programming. When the KEY/PROM switch is in the KEY position, data entered from the keypad is displayed as entered with data entering the right digit position first and moving left. In the PROM position, a programmed EPROM can be verified. A KEY/COPY switch allows data to be accessed from an existing EPROM for copying into a new EPROM. By going to KEY, individual locations can be altered as required.

Addresses are provided by two 74193 counters and displayed as two hexadecimal digits. A CLEAR switch clears both counters to address location 00. A LOAD switch allows the contents of the DATA latches to be entered as an address. A Robinson-Nugent low insertion force socket is provided for the device being programmed. Programming level voltages, addresses, and data are supplied to this socket in the program mode; read level voltages are applied in the verify mode. A similar socket is used for copying. This socket has read level voltages and address information only. The copy data output is selected in lieu of the data latch output using a multiplexer controlled by the KEY/COPY switch. Identical addresses are supplied to both sockets. A PROGRAM PROM POWER switch enables the pulse power supply regulator and timing circuits. With the ADDRESS and

DATA selected, all eight bits of a location are pulsed from 32 to 50 times by circuitry associated with the GO! push-button. The completion of programming is signalled by a COMPARE light followed by automatic address incrementation or decrementation and a READY light. Additional locations are programmed by successively entering DATA and pressing GO!

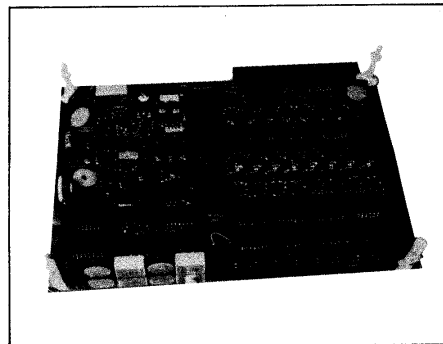

System Description: Profile Card

The Profile card shown above contains the pulse voltage regulators, timing circuits, address drivers, and data drivers/receivers. The high voltage circuitry is protected using a 1 amp fuse and a thyristor "crowbar".

Closed-loop regulation of all pulse voltages is provided by the high voltage regulators and are generated using 9602 monostables controlling high voltage switching transistors. Jumper provisions allow for TRUE or COMPLEMENT input data and TRUE or COMPLEMENT output data.

The address drivers and data drivers/receivers are implemented using a combination of integrated circuits and high voltage transistors. Data input, data output, and control information is provided via the edge connector. Programmed data outputs, address driver outputs, data driver outputs, and other programming voltages are brought to the edge connector for application to the programming socket on the Data Entry card or for Programmed data verification.



Associated Electronics Company

P.O. Box 1720A • 12444 Lambert Circle • Garden Grove, CA 92641 • (714) 539-0735

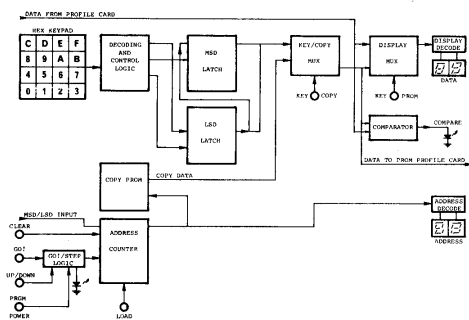

Block Diagram: Data Entry Card

The DATA ENTRY CARD BLOCK DIAGRAM shows the general capabilities for Data Entry. A Hexadecimal Keypad is used to enter Data in a Most Significant and Least Significant Digit Latch via the Decoding and Control Logic.

The Key/Copy Multiplexer selects DATA for use in generating programming pulses from the MSD/LSD latches or from the copy socket. A Display Multiplexer further selects

either the Key/Copy Multiplexer output DATA or verification DATA from the EPROM being programmed for display via the Display Decoder and HEX DATA display. The DATA display is 7-Segment and uses the format 0, 1, 2, 3, 4, 5 . . . 9, A, b, C; d, E, F. Two toggle switches allow selection of KEY/COPY and KEY/PROM.

A pair of 7485 Comparators compare the output of the KEY/COPY MUX with the verification DATA returned from the EPROM being programmed to light a COMPARE LED for programming verification.

The ADDRESS is supplied by two 74193 Up/Down/Counters. These counters can be parallel LOADED from the MSD/LSD latch DATA or CLEARed. The GO/STEP logic is composed of gates and 9602 monostables. Pressing GO! initiates a LOW on the R/W line to activate the Profile Card timing. Upon return to a HIGH on this line, the ADDRESS COUNTER is automatically incremented or decremented depending on the setting of the UP/DOWN toggle switch.

The PGRM POWER toggle switch is used to enable or disable the programming pulse generation circuitry. When disabled, the timing potentiometer on the DATA ENTRY CARD can be set for a short interval and the GO! push-button used to STEP through the addresses for checking an EPROM. Finally, a READY LED lights when the R/W line is HIGH.

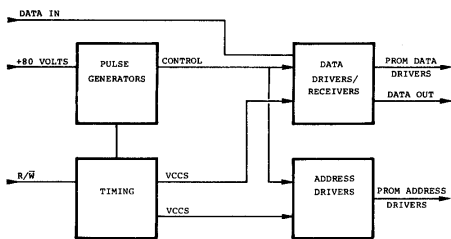

Block Diagram: Profile Card

The PROFILE CARD BLOCK DIAGRAM shown gives the general relation of circuitry on the PROFILE CARD. The timing circuitry consists of three 9602 monostables, one 7400 and one 7404. This circuitry generates a sequence of pulses that results in a chain of 3 millisecond programming pulses separated by 12 millisecond rest periods. This chain continues as long as the R/W line is low.

The resulting pulses are applied to a 7405 driver which drives high voltage transistors in the PULSE GENERATOR

block. These pulses plus DATA and ADDRESS information are used to drive the programming lines to the PROGRAMMING socket.

THE SYSTEM:

The 1702 EPROM PROGRAMMER consists of one DATA ENTRY CARD and one PROFILE CARD stacked on plastic standoffs. The two cards can be wired together or interconnected using a dual 36 pin connector with 0.1 inch center spacing such as the Vector R 636.

External (not supplied) power required is +5 Volts at 2 Amps; -9 Volts at 100 Milliamps; and +80 Volts at 400 Milliamps. The +5 Volts requires good regulation; the -9 Volts can be Zener regulated; and the +80 Volts can be derived from a 50 Volts RMS transformer, a bridge rectifier, and a 100 microfarad, 100 Volt capacitor.

A comprehensive assembly manual, user's manual, and suggested power supply diagram are included with both the kit and assembled unit. A separate power supply is also available.

The kit price is \$189.95

The assembled price is \$299.95

ERRATA

HARDWARE

The transistor orientation images for Q26, Q28, Q29, Q31, Q32, Q33, Q34, Q35, and Q37 are reversed. The instructions to bend the center lead toward the flat face of the transistor are correct but for these nine (9) PE6021s, the flat side of the transistor will be on the opposite side to that indicated by the silk-screened orientation image on the circuit board. These nine (9) transistors are all located in the pulse regulator section of the profile card. (Not applicable to revision 1 and higher.)

Data Entry Card Silk-Screening (Not applicable to revision 1 and higher)

Outputs labeled D00 through D07 should be labeled KCD0 through KCD7 (input to data drivers).

Outputs labeled D0 through D7 should be labeled D00 through D07 (output from data receivers).

SCHEMATICS

Data Entry Card 3 of 3

KCD0 through KCD7 outputs should be shown jumper wired to D0 through D7.



SOLDERING TIPS

- (1) Most soldering tips seen in other kit assembly manuals apply here. Resin core solder (nonacid) must be used in assembly or the warranty will be void.
- (2) The preferred soldering iron for work on these circuit boards is an Ungar Princess with a 15 watt element. A #6961 tip can be used for general work while a #6963 should be used for soldering on integrated circuit pads. A magnifier/lamp combination makes assembly fast and easy.

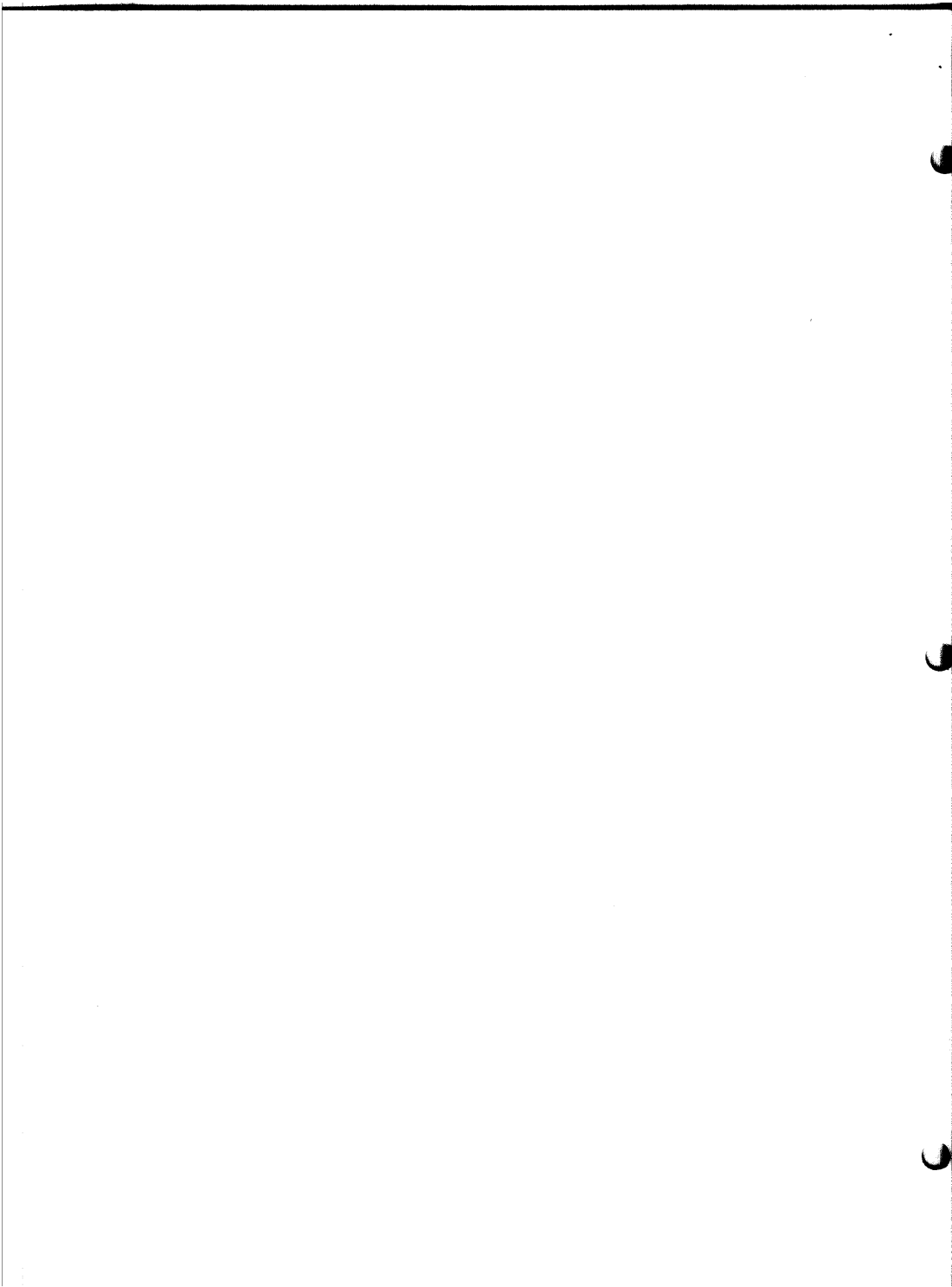

USER'S GUIDE

FINAL ASSEMBLY AND ADJUSTMENT

A suggested power supply is shown in the enclosed schematic. The power requirements are:

+5 volts, 1.2 amps, regulated
-9 volts, 100 milliamps, Zener regulated
+80 volts, 500 milliamps, unregulated

If an Altair or Imsai power source is being used, regulation of the +8 and -16 volt supplies will be required.

The +80 volts can be obtained from two 25 volt, 1 amp Radio Shack transformers, connected in series, aiding a bridge rectifier and a 100 MFD capacitor. For the MCR106-4 over-voltage circuit to operate properly, it will be necessary to install the 1 amp fuse in the +80 volt line.

The +80 volts, with its own ground line, is connected directly to the two pads near R68 on the profile card. The +5, -9, and ground lines can be soldered directly to the connector fingers, to the appropriate traces, or through an edge connector such as the vector #R636 or R636-1.

Testing the Data Entry Card

1. Apply power to the data entry card. The 4 displays should come on. The numbers displayed have no meaning.
2. Set the switches as follows:

KEY/PROM	KEY
KEY/COPY	KEY
PROG POWER	OFF
UP/DOWN	UP
3. Press "CLEAR." The two left digits should read "00" (ADDRESS).
4. Press "0" on the keypad. "0" should appear displayed in the rightmost digit of the two right (DATA) displays. Pressing "1" should move the right digit ("0") left one position and place "1" in the rightmost display ("01").
5. Press "F" twice. The data display should read "FF."
6. Press "LOAD." The address display should read FF."
7. Thumb the top of the trimmer on the data entry card toward you.

8. Press "CLEAR" to get address "00." Now press "GO!." The address should increment with each depression of GO!.
9. Move the UP/DOWN switch to DOWN. Press GO!. The address should decrement with each depression.
10. Thumb the top of the trimmer away from you. Each time GO! is pressed, the READY light should go out for about 1 second.
11. Switch KEY/PROM to PROM. The data display should show "FF." Switch back to KEY.
12. Switch KEY/COPY to COPY. The data display should show "FF." Switch back to KEY.

NOTE

The contents of the key data latches (U9 and U10) will not change during these operations. The outputs of these latches are also tied directly to the parallel load inputs of the address counter. Thus, data displayed in the PROM or COPY positions will not be transferred to the address displays with LOAD operation.

13. Actuate each keypad switch twice, followed by LOAD. This will ensure that each keystroke is being entered correctly and that the data and address display systems are operating.

This completes the general tests of the data entry card.

Inter-card Wiring

If edge connectors are used, simply wire straight across... pin 1 to pin 1 and so forth, on the connector.

If connectors are not used, an extra set of small holes are incorporated near the edge connectors. An extra hank of wire labeled "Inter-card Wiring Wire" has been included with each kit. This should be cut into seventy-two 6 inch lengths, stripped, and connected from pin 1 on the data entry to pin 1 on the profile card and so forth.

Testing and Adjusting the Profile Card

1. Turn the leftmost trimmer (facing left) toward you to its limit. This reduces VCCS to a safe level.
2. Turn on all power. It is recommended that if separate switches are being used for the supplies +5 and -9 should be turned on first, followed by the plus 80 volt supply.
3. Connect an oscilloscope to pin 9 of U15 and adjust R104 (the right trimmer at the bottom of the card) for a 3.0 millisecond pulse by activating GO! as necessary. Be sure the PROG POWER switch is off.
4. Connect the oscilloscope to pin 10 of U14 and adjust R100 (the left trimmer) for a 3.25 millisecond pulse by activating GO! as necessary.
5. Set the scope for 10 volts per division. Connect the probe to VCCS (preferably at the PROGRAM socket).
6. Turn PROG POWER on. Activate GO! and carefully adjust R87 (left center of profile card) for a pulse of between 46 and 48 volts amplitude. Note that VCCS is already 5 volts and the pulse should be at roughly 47 volts above ground. Although 46.7 volts is recommended, it does not appear to be excessively critical.
7. Check the remaining voltages at the socket to ensure that they are statically at one level as indicated on the profile card and actively reach the other level indicated when the GO! button is pushed. The address and PRGM waveforms may look odd since the address is complemented for 60 microseconds, then made true until near the end of the 3.0 millisecond period, then complemented for another 60 microseconds before being turned off.

You are now ready to program an EPROM. For true data in and out, install a jumper from the top of R67 to ground. Pads are provided for this purpose.

Programming

1. Turn off all power. Insert the 1702A in the program socket (center socket) with pin 1 to the left - away from the keypad.

CAUTION

Reversing the EPROM in the socket will destroy it if an attempt is made to program it this way. It may also damage the programmer pulse regulators.

2. Set the switches as follows:

KEY/PROM	KEY
KEY/COPY	KEY
UP/DOWN	UP
PROG POWER	OFF

3. Apply power to the programmer.
4. Advance the trimmer on the data entry card (thumb it up) to about 3/4ths of its rotation (or measure 32 pulses with your scope). The actual number does not appear to be critical although too many hits may shorten the programming cycle life of the device.
5. Clear the address counter or load the desired address.
6. Enter the desired data.
7. Turn PROG POWER on.
8. Activate GO!. The READY light should go out. The COMPARE should come on almost immediately indicating a comparison of the input data with the programmed data. The address will then increment, the COMPARE lamp will go out and the READY light will come on indicating that programming is complete.
9. If you would like to check the results, turn PROG POWER off. Return the address counter to "00" or whatever starting location you used and switch KEY/PROM to PROM. The data contained at the location will be displayed.

To COPY an EPROM

1. Turn power off.
2. Put the EPROM to be copied in the COPY socket (upper right socket) with pin 1 to the left.
3. Put the EPROM to be programmed in the PROGRAM socket.
4. Set the switches as for programming with the exception being the KEY/COPY switch which should be in the COPY position.
5. Set the address to the starting location, turn on PROG POWER, and activate GO!. Each time READY comes on, again activate GO!. Each location in the COPY EPROM will be duplicated in the fresh device.

Erasing an EPROM

A source of short-wave ultraviolet light such as the UVS-11 available from Ultra-Violet Products Inc., 5114 Walnut Grove Avenue, San Gabriel, California, is required to erase the 1702A. The filter should be removed from this light and the 1702A exposed for 10 to 20 minutes at a distance of 1 inch from the source. Follow the precautions included with the ultraviolet source.

Additionally, for the cost of transportation, Associated Electronics will erase your EPROMs for you. Just mail them to us, securely packaged. Include your name and address plus return postage.

ASSEMBLY OF THE 1702 EPROM PROGRAMMER

Carefully unpack and check the parts received with your kit. All parts have been individually packed and labeled to keep confusion to a minimum. Please do not disassociate parts and labels during the unpacking process until the parts are to be installed. Some of the resistor color codes, for example, are difficult to read.

Electrolytic capacitors may have higher voltage ratings than those given in the parts list but this is perfectly acceptable. Again, use the parts contained in the packages with labels corresponding to the parts list.

Assembly of the Profile Card

Locate the profile card. It should be stamped on the reverse side with the number 760415-1200. The silk-screened side is the components side. Lay the card on your workspace and look it over to become familiar with the layout and general location of parts. With the printed circuit finger connector located in the upper right corner, the address drivers are located in the upper right quadrant of the board. The data drivers are located in the lower right-hand quadrant and consist of U3 through U10 and Q9 through Q24. Data input and output lines to the fingers, as well as program socket drive lines will be wire jumpers. Address driver input lines will also be wire jumpers while the address driver output lines to the program socket are already present on the board.

The timing circuitry for the pulse power supply is located in the lower left-hand quadrant and the actual pulse regulator circuitry is located in the upper left-hand quadrant. The raw 80 volt dc input is connected via two large pads located about 1/2 inch down in the extreme upper left-hand corner just above and to the left of R68.

Figure 1 shows the connector layout and numbering scheme. Notice that odd numbered fingers are on the component side while even numbered fingers are on the solder side with plated through connection to pads located between the odd fingers. In this arrangement the pad numbering proceeds sequentially across the board. The +5 volt fingers and traces are on the component side of the board while the ground fingers and trace are on the solder side. Table 1 gives a complete list of the connector pin assignments.



Figure 2. Connector Layout and Numbering Scheme

PIN NUMBER	FUNCTION	PIN NUMBER	FUNCTION
1	+5 Volts	37	Data 1 to PRG Socket
2	Ground	38	Data 0 to PRG Socket
3	+5 Volts	39	Address 0 to Drivers
4	Ground	40	Address 1 to Drivers
5	+5 Volts	41	Address 2 to Drivers
6	Ground	42	Address 3 to Drivers
7	Not Used	43	Address 4 to Drivers
8	Not Used	44	Address 5 to Drivers
9	Not Used	45	Address 6 to Drivers
10	Not Used	46	Address 7 to Drivers
11	Not Used	47	Not Used
12	Not Used	48	Not Used
13	Not Used	49	Not Used
14	Not Used	50	Address 0 to PRG Socket
15	Data 7 to Drivers	51	Address 1 to PRG Socket
16	Data 6 to Drivers	52	Address 2 to PRG Socket
17	Data 5 to Drivers	53	Address 3 to PRG Socket
18	Data 4 to Drivers	54	Address 4 to PRG Socket
19	Data 3 to Drivers	55	Address 5 to PRG Socket
20	Data 2 to Drivers	56	Address 6 to PRG Socket
21	Data 1 to Drivers	57	Address 7 to PRG Socket
22	Data 0 to Drivers	58	Not Used
23	Data 7 from Receivers	59	Not Used
24	Data 6 from Receivers	60	Not Used
25	Data 5 from Receivers	61	VCCS
26	Data 4 from Receivers	62	Not Used
27	Data 3 from Receivers	63	Not Used
28	Data 2 from Receivers	64	VDD
29	Data 1 from Receivers	65	VGG
30	Data 0 from Receivers	66	CS*
31	Data 7 to PRG Socket	67	PRGM
32	Data 6 to PRG Socket	68	VBB
33	Data 5 to PRG Socket	69	-9 Volts
34	Data 4 to PRG Socket	70	Program PROM Power
35	Data 3 to PRG Socket	71	R/W* 1702
36	Data 2 to PRG Socket	72	R/W* 1702A

Table 1. Edge Connector Pin Assignments

- (✓) Remove eight 6.8 K resistors. Bend the leads close to the body of the resistor and install in locations R1 through R8. Solder and trim excess lead length.
- (✓) Remove eight 330 ohm resistors. Bend the leads close to the body of the resistor and install in locations R9 through R16. Solder and trim excess lead length.
- (✓) Remove eight 100 ohm resistors. Bend the leads close to the body of the resistor and install in locations R17 through R24. In soldering these pads, be careful that you do not fill the pad holes near one end of each resistor. These will be used later to wire the edge connector. Solder and trim excess lead length.
- (✓) Remove eight 6.8 K resistors. Bend the leads close to the body of the resistor and install in locations R25 through R32. Solder and trim excess lead length.
- (✓) Remove eight 1 K resistors. Bend the leads close to the body of the resistor and install in locations R33 through R40. The large pads should be used at all times. Avoid installing these resistors with either lead in the small holes located between the two large pads. Solder and trim excess lead length.
- (✓) Remove eight 1 K resistors. Bend the leads close to the body of the resistor and install in locations R41 through R48. Solder and trim excess lead length.
- (✓) Remove the last eight 6.8 K resistors. Bend the leads close to the body of the resistor and install in locations R49 through R56. Solder and trim excess lead length.
- (✓) Remove eleven 5.6 K resistors. Bend the leads close to the body of the resistor and install in locations R57 through R67. Eight of these locations are across the bottom right edge of the card while three are located at the bottom center (installed vertically). Solder and trim excess lead length.
- (✓) Remove one 470 ohm resistor. Bend the leads close to the body of the resistor and install in location R70. (R68 and R69 will be installed later.) Solder and trim excess lead length.
- (✓) Remove one 1 K resistor. Bend the leads close to the body of the resistor and install in location R71. Solder and trim excess lead length.
- (✓) Remove the 33 K resistor. Bend the leads close to the body of the resistor and install in location R72. Solder and trim excess lead length.

- (✓) Remove one 10 K resistor. Bend the leads close to the body of the resistor and install in location R73. Solder and trim excess lead length.
- (✓) Remove the 390 ohm resistor. Bend the leads close to the body of the resistor and install in location R74. Solder and trim excess lead length.
- (✓) Remove one 1 K resistor. Bend the leads close to the body of the resistor and install in location R75. Solder and trim excess lead length.
- (✓) Remove the 220 ohm resistor. Bend the leads close to the body of the resistor and install in location R76. Solder and trim excess lead length.
- (✓) Remove one 10 K resistor. Bend the leads close to the body of the resistor and install in location R77. Solder and trim excess lead length.
- (✓) Remove the 100 K resistor. Bend the leads close to the body of the resistor and install in location R78. Solder and trim excess lead length.
- (✓) Remove one 10 K resistor. Bend the leads close to the body of the resistor and install in location R79. Solder and trim excess lead length.
- (✓) Remove one 4.7 K resistor. Bend the leads close to the body of the resistor and install in location R80. Solder and trim excess lead length.
- (✓) Remove one 4.7 K resistor. Bend the leads close to the body of the resistor and install in location R81. Solder and trim excess lead length.
- (✓) Remove the last 330 ohm resistor. Bend the leads close to the body of the resistor and install in location R82. Solder and trim excess lead length.
- (✓) Remove one 4.7 K resistor. Bend the leads close to the body of the resistor and install in location R83. Solder and trim excess lead length.
- (✓) Remove the 22 ohm resistor. Bend the leads close to the body of the resistor and install in location R84. Solder and trim excess lead length.
- (✓) Remove one 4.7 K resistor. Bend the leads close to the body of the resistor and install in location R85. Solder only the lead at the end nearest the edge connector at this time...the other end will be soldered at a later time. Trim the excess lead from the soldered end and cut the unsoldered lead to about 1/2 inch long.

- (✓) Remove one 10 K resistor. Bend the leads close to the body of the resistor and install at location R86, near the left edge at the center of the card. Solder and trim excess lead length.
- (✓) Remove one 10 K resistor. Bend the leads close to the body of the resistor and install at location R88 (R87 will be installed in a later step). Solder and trim excess lead length.
- (✓) Remove the last 100 ohm resistor. Bend the leads close to the body of the resistor and install at location R89. Solder and trim excess lead length.
- (✓) Remove one 470 ohm resistor. Bend the leads close to the body of the resistor and install at location R90. Solder and trim excess lead length.
- (✓) Remove one 4.7 K resistor. Bend the leads close to the body of the resistor and install at location R92 (R91 will be installed in a later step). Solder and trim excess lead length.
- (✓) Remove one 27 K resistor. Bend the leads close to the body of the resistor and install at location R93. Solder and trim excess lead length.
- (✓) Remove one 1 K resistor. Bend the leads close to the body of the resistor and install at location R94. Solder and trim excess lead length.
- (✓) Remove one 1 K resistor. Bend the leads close to the body of the resistor and install at location R95. Solder and trim excess lead length.
- (✓) Remove the last two 5.6 K resistors. Bend the leads close to the body of the resistors and install at locations R96 and R97. Solder and trim excess lead length.
- (✓) Remove the two 20 K resistors. Bend the leads close to the body of the resistors and install at locations R98 and R99. At location R99, be sure the resistor lead at the left end does not go into the pad for CR14. Also, in soldering, be careful that a solder bridge is not formed between the narrow pad and the traces running on either side of it. Solder all four leads and cut off the excess length.
- (✓) Remove one 4.7 K resistor. Bend the leads close to the body of the resistor and install at location R101 (R100 will be installed in a later step). Solder and trim excess lead length.

- (✓) Remove the 12 K resistor. Bend the leads close to the body of the resistor and install at location R102. Solder and trim excess lead length.
- (✓) Remove one 10 K resistor. Bend the leads close to the body of the resistor and install at location R103. Solder and trim excess lead length.
- (✓) Remove one 4.7 K resistor. Bend the leads close to the body of the resistor and install at location R105 (R104 will be installed in a later step). Solder and trim excess lead length.
- (✓) Remove the last two 27 K resistors. Bend the leads close to the bodies of the resistors and install at locations R106 and R107. Solder and trim excess lead length.
- (✓) Remove one 470 ohm resistor. Bend the leads close to the body of the resistor and install at location R108. Solder and trim excess lead length.
- (✓) Remove two 4.7 K resistors. Bend the leads close to the body of each resistor and install at locations R109 and R110. Solder and trim excess lead length.

Installing Integrated Circuits

The installation of integrated circuits can be very difficult if improperly done. The process known as "walking" the integrated circuit in can be both difficult and tedious besides causing lead damage. The following method is recommended.

First, examine the leads to insure that the spacing between leads is reasonably uniform. Now, take the integrated circuit between the thumb and forefinger of both hands with the forefingers on the bottom ends between the leads and the thumbs on top near one edge. Place the leads on one side firmly against a resilient surface such as writing pad. Apply pressure to the integrated circuit such that the leads on the bottom are forced toward the leads on the top. Turn the integrated circuit over and repeat the process on the other row of leads. The idea is to force both rows of leads in an equal amount until the rows are spaced 0.3 inches at the tips. Overbending is difficult to correct so use light pressure at first, increasing it as required to cause the leads to bend at the near 90 degree point where they exit from the integrated circuit package.

- () In the following steps, bend the leads as indicated and insert the integrated circuit at the location indicated. Each integrated circuit will have either a notch or a small circular depression at the pin 1 end. This should be oriented to match the notch of the silk-screened image on the board. On this card all notches are to the left.

- () Remove one 7400 IC. Install it at location U12 and solder.
- () Remove four 7403 ICs. Install them at locations U3, U5, U8, and U10. Solder all pins.
- () Remove one 7404 IC. Install it at location U11 and solder.
- () Remove the 7405 IC. Install it at location U16 and solder.
- () Remove the six 7486 ICs. Install them at locations U1, U2, U4, U6, U7, and U9. Solder all pins.
- () Remove three 9602 ICs. Install them at locations U13, U14, and U15. Solder all pins.
- () Remove the NE550 IC. Install it at location U17 and solder.

Installing Diodes

Diodes are polarity sensitive devices. They must be installed with this in mind. Most diodes have a band on one end of the body indicating the cathode end of the diode. The symbol used on the circuit boards is a conventional diode symbol consisting of an arrow with a bar across the top. This bar indicates the cathode end. Each diode should be installed with the banded end of the diode connected to the pad nearest the bar of the symbol. Another way to look at it is that the arrow points to the pad to which the banded end should be connected.

The bands on the diodes in your kit may be one of several colors and they may not always be directly on the edge of the body but they will always be nearest the cathode end. Additionally, the 1N914 equivalents you receive may be from a reel. In this case the cathode end is the end attached to the blue tape.

- (✓) When installing diodes, bend the leads to fit the pad spacing. Always support the leads with a pair of needle nose pliers between the bent point and the glass body. Failure to do so can result in fractured end seals or damaged bodies.
- () Remove the two 1N5258 zener diodes. Install them at the locations marked CR1 and CR11. The band on CR1 should be oriented to the left (with the component side up and the edge connections at the upper right), while the band on CR11 should be oriented toward the bottom of the card. Solder and trim excess lead length.
- (✓) Remove the 1N4002 diode. Install it at the location marked CR2. Solder and trim excess lead length.

- (✓) Remove the 1N5263 zener diode. Install it at the location marked CR3. The cathode band should be to the left. Solder and trim excess lead length.
- (✓) Remove the 1N5242 zener diode. Install it at the location marked CR4. The cathode band should be to the left. Solder and trim excess lead length.
- (✓) Remove seven 1N914 or equal. Install them at locations marked CR5, CR6, CR8, CR10, CR12, CR13, and CR14. Orient the cathodes as indicated in the screened images on the board. Solder all leads and trim excess lead length.
- (✓) Remove the 1N5264 zener diode. Install it at the location marked CR7. Solder and trim excess lead length.
- (✓) Remove the 1N5231 zener diode. Install it at the location marked CR9. Solder and trim excess lead length.

Installing Power Resistors

- (✓) Remove the 8.2 K, 1 watt resistor. Bend the leads close to the body of the resistor and install in the location marked R91. Solder and trim excess lead length.
- (✓) Remove the 1/2 ohm, 2 watt resistor. Bend the leads to conform to the pad spacing on the board and install at the location marked R69. Solder and trim excess lead length.
- (✓) Remove the 5 ohm, 5 watt resistor. Bend the leads close to the body of the resistor and install at the location marked R68. Space the body of the resistor about 1/8 inch above the surface of the board. Solder the lead nearest the left edge of the board. Cut the other lead to about 1/2 inch in length and bend it down flat against the board so that it extends about 1/4 inch over the large pad under Q25. DO solder this lead at this time.

Installing Transistors

- (✓) Remove twenty-four PE6021 transistors. Bend the center lead toward the flat side of each transistor and install them in locations marked Q1 through Q24. The orientation of the transistor should conform to the silk-screened image on the circuit board. Press each transistor down to within 1/8 inch of the board. Solder and trim excess lead length.

- (✓) Remove the last nine PE6021 transistors. Bend the center lead toward the flat side of each transistor and install them in locations marked Q26, Q28, Q29, Q31, Q32, Q33, Q34, Q35, and Q37. The orientation of the transistor should conform to the silk-screened image on the circuit board. Press each transistor down to within 1/8 inch of the board. Solder and trim excess lead length.
- (✓) Remove the 2N2907 (PE2907) transistors. Bend the center lead slightly toward the flat side of each transistor and install them in locations marked Q30 and Q36. The orientation of the transistor should conform to the silk-screened image on the circuit board. Press each transistor down to within approximately 1/8 inch of the board. Solder and trim excess lead length.
- (✓) Remove the 2N4920 and its associated hardware. The hardware should consist of one screw, one nut, one cup washer and a nearly invisible mica washer. Using a sharp pair of diagonal cutters, remove about 1/8 inch from the edge of the mica washer to allow it to clear CR2. The mica washer goes between the metal face of the 2N4920 and the circuit board. Bend the leads of the transistor at right angles toward the metal face of the transistor. These should be bent so that the pattern conforms to the pattern of holes on the PC board and spaced so the 4-40 screw will go through the transistor, mica washer and circuit board. The cup washer should be placed with the cup toward the transistor allowing the rim of the cup washer to rest on the transistor. This transistor should be installed at location Q27. Put the 4-40 screw through this assembly and install the nut on the solder side. Tighten the screw enough to immobilize the assembly, then take the nut in a pair of pliers and, making sure the nut clears surrounding circuit traces, tighten the screw firmly. Solder the transistor leads on the solder side of the board and trim excess lead length.
- (✓) In a similar manner, remove and install the MCR106-4 at the location marked SCR1.
- (✓) Remove the MJE6045. This a heavy-duty Darlington regulator. The leads are quite stiff and the proper bend point is about 3/32 inch from the body of the transistor. Again the bend is toward the metal side of the transistor body and the body should be supported firmly at the lead exit to prevent fracturing. Cut the tips of the leads at a slight angle to allow easier insertion. Trim 1/8 inch from each side of the mica washer and install as before. Pull the leads through, as required, with long nose pliers until the transistor is firmly seated and flat on the board (separated by the mica washer). Tighten the screw while holding the nut in a position that clears the trace running near the large pad on the solder side of the board. Bend the lead from R68 so that it clears the nut and solder it at the pad and to the large pad under the MJE 6045.

Installing the Trimmer Resistors

- (✓) Remove the 10 K trimmer. Press it into place at location marked R87. Solder the leads on the solder side.
- (✓) Remove the two 20 K trimmers. Press them into place at locations marked R100 and R104. Solder the leads.

Installing Capacitors (Electrolytic)

- (✓) Remove the 2.2 mF capacitor. Observe polarity. In the device supplied, the negative end is marked with a black band. The positive end will always be the end that comes through an insulating sealer and will normally be marked +. In this case, the positive (unbanded) end goes to the left. Install the capacitor at the location marked C13. Solder and trim excess lead length.
- (✓) Remove two 5 mF, 16 volt capacitors (marked 4.7 mF, 35 V). Observe polarity and install these at locations marked C4 and C19. Solder and trim excess lead length.
- (✓) Remove two 5 mF, 50 volt capacitors (marked 4.7 mF, 50 V). Observe polarity and install these at locations marked C1 and C9. Solder and trim excess lead length.
- (✓) Remove the 22 mF, 16 volt capacitor. Observe polarity and install at location marked C14. Solder and trim excess lead length.

Installing Capacitors (Ceramic and Mylar)

- (✓) On all ceramic capacitors, gently crush the coating material that extends down the leads and scrape the leads clean with a craft knife.
- (✓) Remove the 100 pF ceramic capacitor. Install it in the location marked C8. Solder and trim excess lead length.
- (✓) Remove the three 200 pF ceramic capacitors. Install them in locations marked C2, C5, and C10. Solder and trim excess lead length.
- (✓) Remove the four .001 mF ceramic capacitors. On C7 lay the lead nearest R85 alongside the unsoldered lead of R85. Solder both pads and leads to form a bridge. Install them in locations marked C7, C11, C22, and C23. Solder and trim excess lead length.
- (✓) Remove one .01 mF ceramic capacitor. Install it at the location marked C3. Solder and trim excess lead length.

- (.) Remove the .05 mF ceramic capacitor. Install it at the location marked C6. Solder and trim excess lead length.
- (✓) Remove the three .1 mF ceramic capacitors. Install them in locations marked C12, C20, and C21. Solder and trim excess lead length.
- (.) Remove the .02 mF mylar capacitor (marked .022). Install at the location marked C17. Solder and trim excess lead length.
- (.) Remove the .05 m mylar capacitor (marked .047). Install at the location marked C16. Solder and trim excess lead length.
- (✓) Remove the two 1 mF capacitors. Install them at locations marked C15 and C18. Solder and trim excess lead length.

Installing Wire Jumpers

- () Cut eight lengths of wire approximately 2-1/2 inches long. Strip 1/4 inch of insulation from each end. These wires may be installed on either the component or solder side of the circuit board. Figure 2 shows the installation on the solder side. Install the wires one at a time and solder each one with the insulation as near the pad as possible. Cut any excess wire as close to the pad as possible. Be extremely careful that all clippings are removed. Refer to Figure 1 and Table 1 as required to resolve any problems.
- () Cut eight lengths of wire approximately 4-1/2 inches long. Strip 1/4 inch of insulation from each end. Install the wires as shown in Figure 3. Solder and cut off excess lead length.
- (✓) Cut sixteen lengths of wire approximately 7 inches long. Strip 1/4 inch of insulation from each end. Install eight of these as shown in Figure 4. Solder and cut off excess lead length.
- () Install the remaining eight wires as shown in Figure 5. Solder and cut off excess lead length.
- () Locate four white plastic standoffs. Install the large end of each of these in one of the corner holes on the circuit board. This completes the wiring of the profile board. Set it aside until called for.

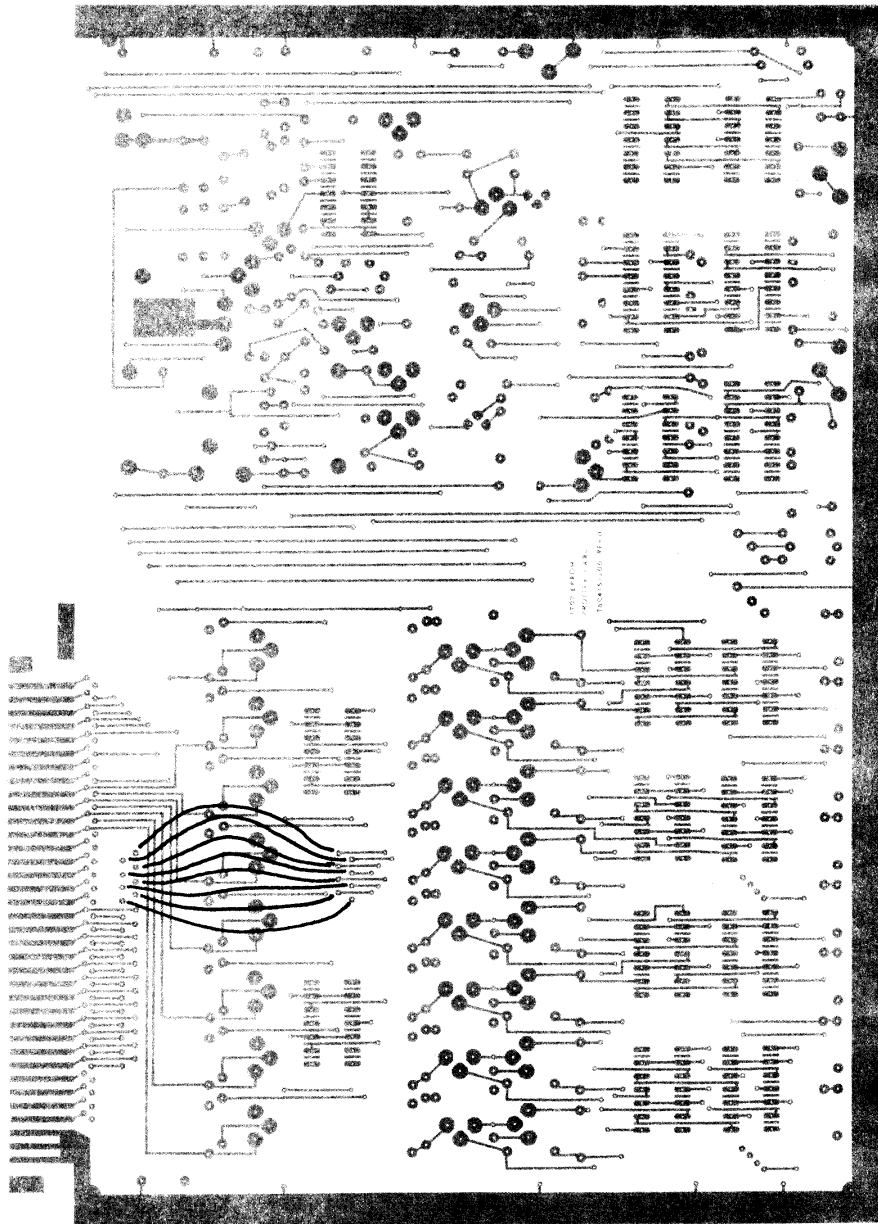

Figure 2. Address Input Wiring

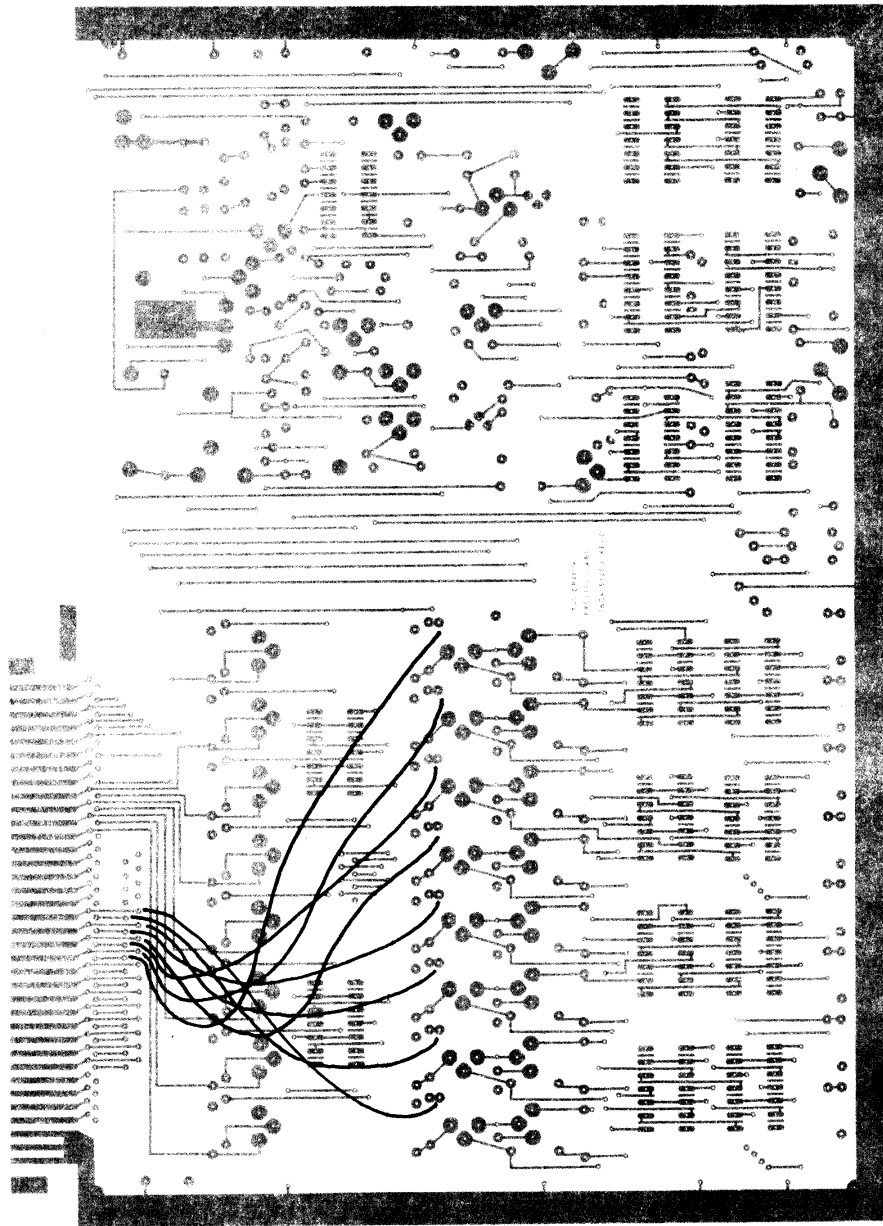

Figure 3. Data to PROGRAM SOCKET Wiring

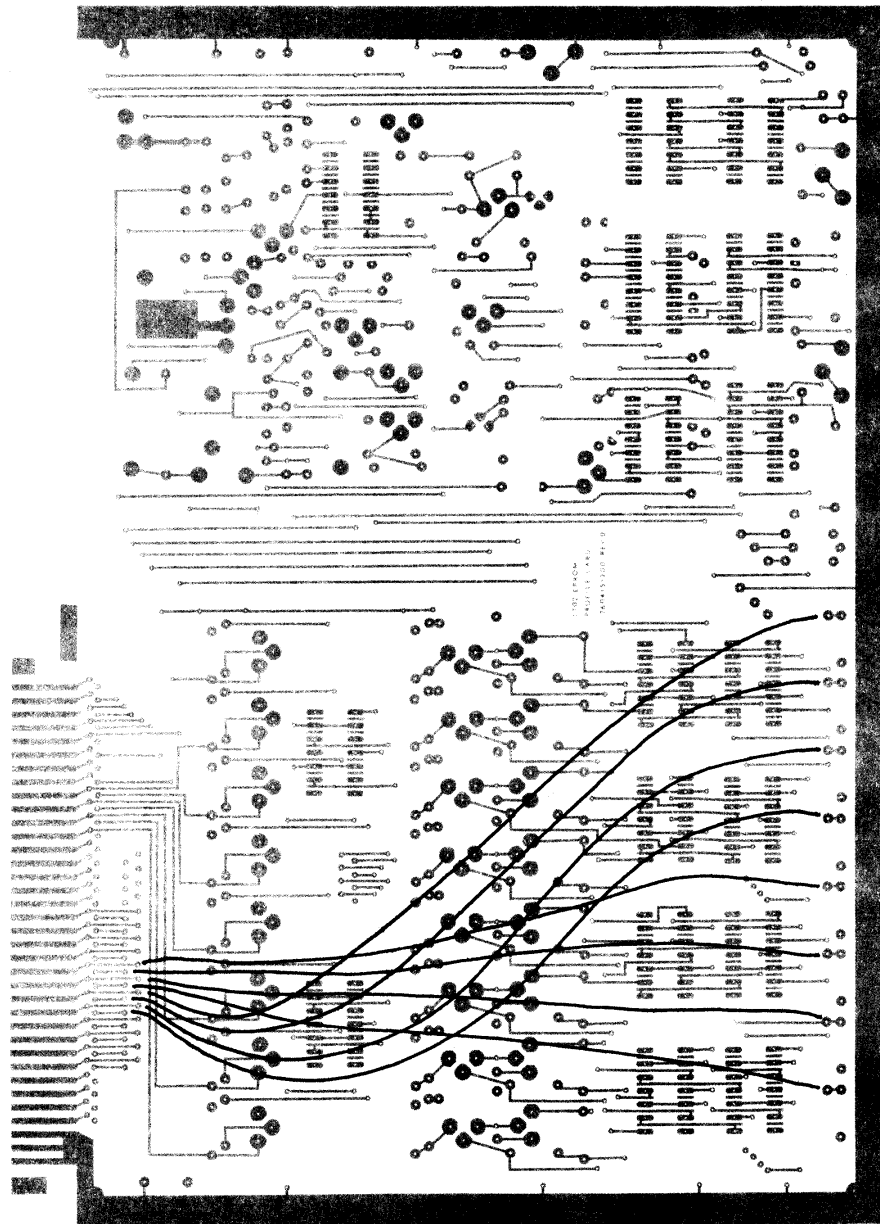

Figure 4. Output from Data Receiver Wiring

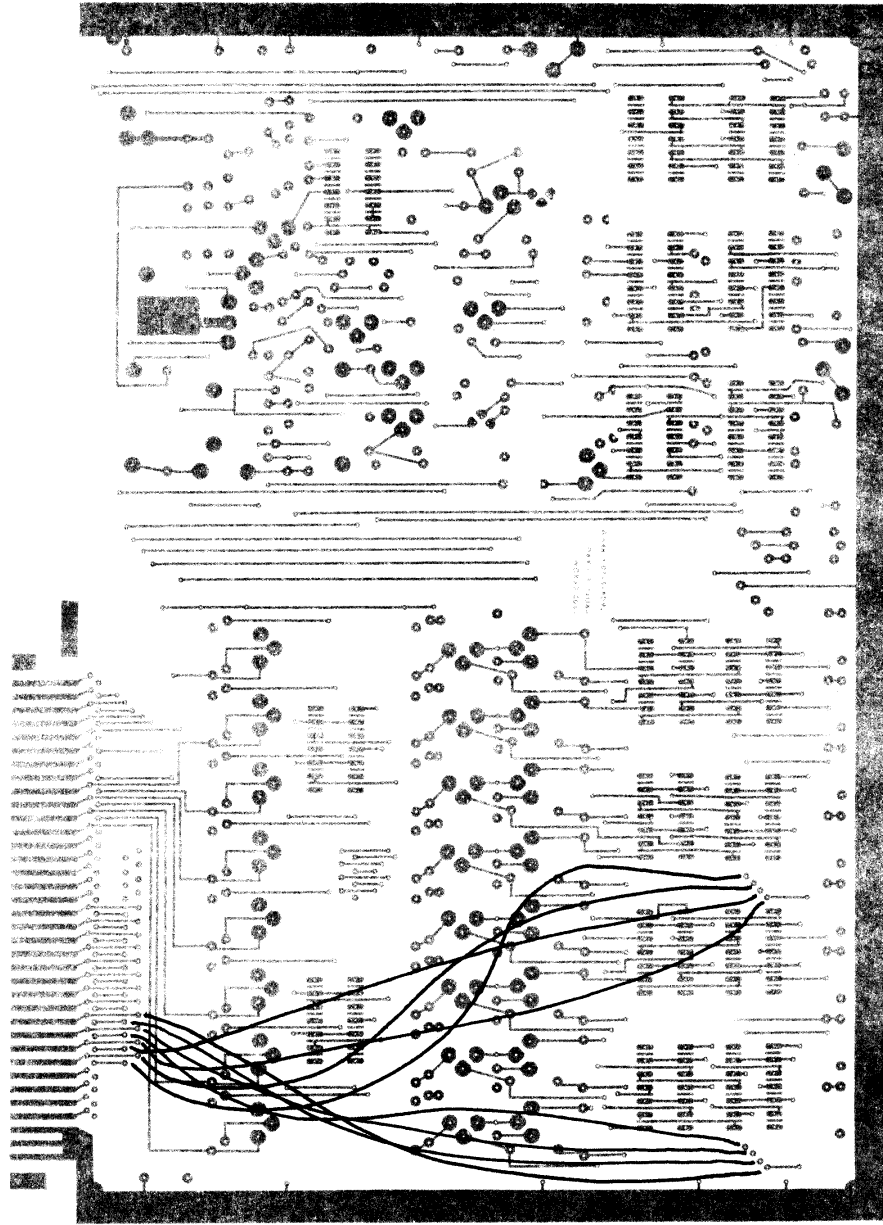

Figure 5. Data Input Drivers Wiring

ASSEMBLING THE DATA ENTRY CIRCUIT BOARD

Installing Resistors

- (✓) Remove the last two 470 ohm resistors. Bend the leads close to the body of the resistor and install in locations labeled R8 and R13 (near READY and COMPARE LEDs). Solder and trim excess lead length.
- (✓) Remove the last eight 1 K resistors. Bend the leads close to the body of the resistor and install in locations labeled R2, R4, R5, R6, R7, R9, R14, and R15. Solder and trim excess lead length.
- (✓) Remove the last 4.7 K resistor. Bend the leads close to the body of the resistor and install in the location labeled R11. Solder and trim excess lead length.
- (✓) Remove the last two 10 K resistors. Bend the leads close to the body of the resistor and install in locations labeled R1 and R10. Solder and trim excess lead length.
- (✓) Remove the 47 K resistor. Bend the leads close to the body of the resistor and install in the location labeled R3. Solder and trim excess lead length.

Installing Diodes

- (✓) Remove the last four 1N914 diodes. Following the general comments on page 8, install these diodes at locations marked CR1, CR2, CR3, and CR4. Solder and trim excess lead length.

Installing Integrated Circuits

- () Follow the general notes on installing integrated circuits on page 7.
- () Remove the last three 7400 ICs. Install in locations labeled U5, U15, and U19. The orientation marks on each of these devices should be toward the edge connector. Solder all leads.
- () Remove the last 7404 IC. Install it in the location labeled U1. The orientation mark on this device should be toward the edge connector. Solder all leads.
- () Remove the 7410 IC. Install it in the location labeled U6. The orientation mark on this device should be toward the edge connector. Solder all leads.

- () Remove the two 7475 ICs. Install in locations labeled U9 and U10. The orientation marks on these devices should be toward the edge connector. Solder all leads.
- () Remove the two 7476 ICs. Install in locations labeled U2 and U4. The orientation marks on these devices should be toward the edge connector. Solder all leads.
- () Remove the two 7485 ICs. Install in locations labeled U16 and U17. The orientation marks on these devices should be toward the edge connector. Solder all leads.
- () Remove the 7493 IC. (Do not confuse this device with the 74193!!!!!!.) Install it in the location labeled U7. The orientation mark should be toward the edge connector. Solder all leads.
- () Remove the 74154 IC. Install it in the location labeled U8. The orientation mark ---- PAY ATTENTION ---- should be down...away from the edge connector. Solder all leads.
- () Remove the four 74157 ICs. Install in locations labeled U11, U12, U20, and U21. The orientation marks on these devices should be toward the edge connector. Solder all leads.
- () Remove the two 74193 ICs. Install in locations labeled U13 and U14. The orientation marks should be toward the left edge of the circuit board. Solder all leads.
- () Remove the four 9368 ICs. Install in locations labeled U22, U23, U24, and U25. The orientation marks ---- AGAIN PAY ATTENTION ---- should be toward the right edge of the circuit board. Solder all leads.
- () Remove the last two 9602 ICs. Install in locations labeled U3 and U18. The orientation marks on these two devices should be ---- DOWN ---- away from the edge connector. Solder all leads.

Installing Capacitors (Ceramic)

- (✓) Remove the last .01 mF capacitor. Install it in the location marked C1 after removing the excess material from the leads. This device is best laid flat against the circuit board. Solder and trim excess lead length.

Installing Capacitors (Electrolytic)

Follow the general comments on electrolytic capacitor installation from page 11.

- (✓) Remove the three 10 mF capacitors. Install these at locations marked C2, C3, and C4. The positive end should be up toward the edge connector on each of these devices. Solder and trim excess lead length.
- (✓) Remove the 50 mF capacitor. Install it in the location marked C5. The positive end is up, toward the edge connector. Solder and trim excess lead length.

Miscellaneous

- (✓) Remove the 50 K trimmer. Install it at the location marked R12. Press the leads in until the shoulders seat against the board and solder all three leads.
- (✓) Remove the two LEDs. These are small 1/8 inch diameter Light Emitting Diodes. Install them at the location and as indicated in Figure 6. The cathode lead can be identified by a flat portion on the base of the LED next to the cathode or by the fact that the cathode lead is longer. Support the leads at the base where they leave the body of the LED and bend them back so that the entire assembly can be inserted from the rear of the circuit board. The 1/8 inch holes in the board may have to be enlarged slightly by reaming them with a 1/8 inch drill or a craft knife. Align the leads with the holes indicated in Figure 6 and slide the entire assembly down so the rim of the LED is flush with the back surface of the board. Solder the leads from the solder side. Turn the board over and trim the leads flush with the component side.
- () Remove four FND500 seven segment displays. To protect the faces, it is recommended that a piece of masking tape be cut to size and applied before actual assembly of the devices to the board. The top of each FND500 is identified by four (4) notches. The devices should be installed in the locations marked DISP1, DISP2, DISP3, and DISP4 with these notches oriented toward the edge connector. The leads of each device are spread slightly but by inserting one row of leads partially through the board and forcing the device gently in that direction, the other row of leads should be easy to insert. Once inserted, turn the board over and solder diagonally opposite corners of each device. Now apply finger pressure to the center of each device and melt the solder to allow the device to be pressed flush to surface of the board. Solder all leads.

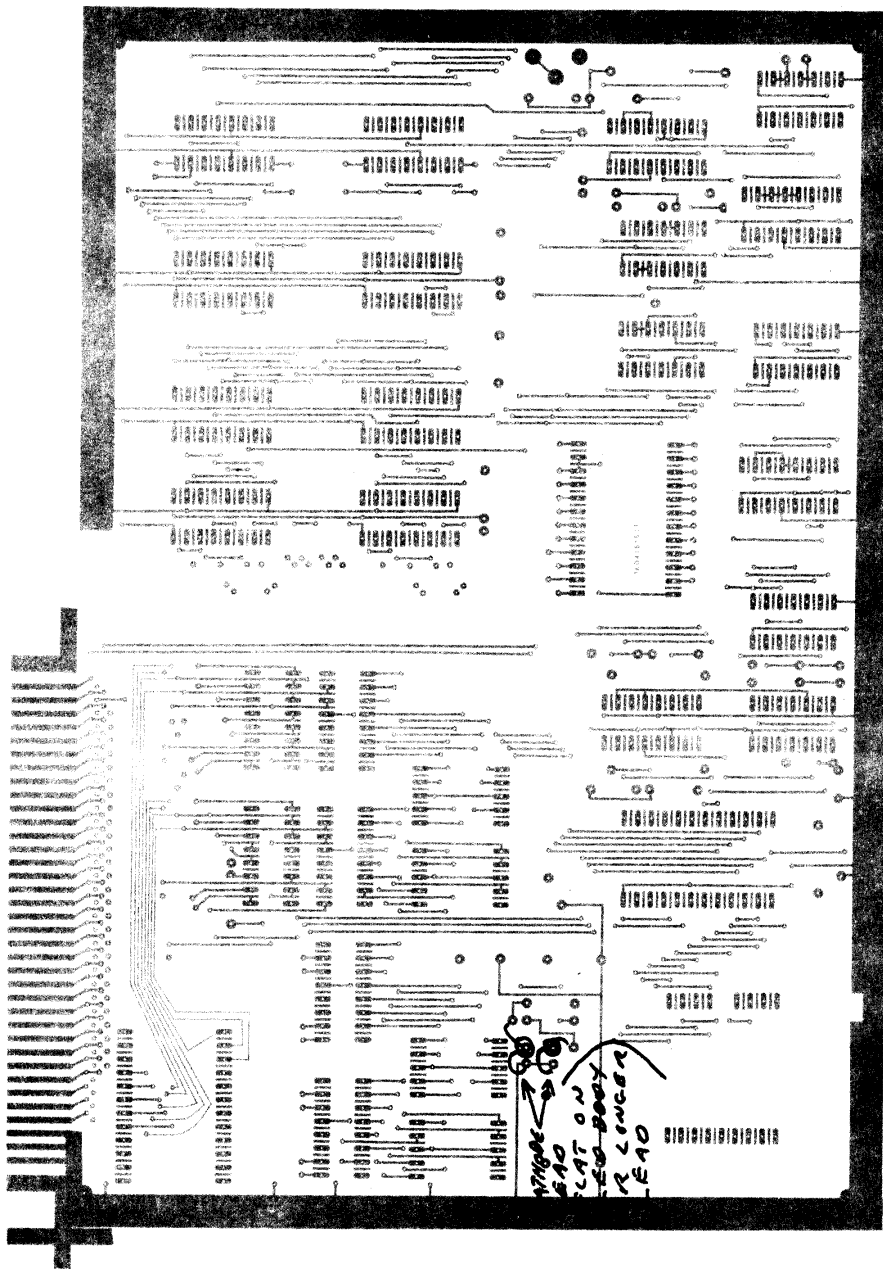

Figure 6. LED Installation

Installation of Toggle Switches

- (✓) Remove four toggle switches. Install in the holes indicated in Figure 7. Remove all hardware except the two nuts. Adjust one nut to allow the threads of the switch bushing to extend above the card by about 1/8 inch. Push the switch through from the solder side of the circuit board and put the other nut on and tighten it down. All switches should be installed with the contacts in a vertical row (with the top of the circuit board being the edge that contains the edge connector). Make certain that the bottom nut does not contact circuit traces.
- (✓) Cut four 1-1/2 inch pieces of wire. Strip 1/16th to 1/8th of an inch of insulation from each end. Connect and solder one end to the center contact of each toggle switch. Connect the other end to the appropriate solder pad as indicated in Figure 7.

Installing Push Button Switches

- (.) Remove three push button switches. Install them in the holes indicated in Figure 8. Tighten each nut firmly but without undue force. Align the contact vertically as before.
- (.) Cut three 1-1/2 inch pieces of wire. Strip 1/16th to 1/8th of an inch of insulation from each end. Connect and solder one end to the bottom contact of each switch. Connect the other end to the solder pad indicated in Figure 8.

Wiring Switches

- (✓) Cut a 7-1/2 inch length of wire. Strip 1/8th inch of insulation from each end. Connect one end to the contact indicated on switch S7. Connect the other end to the pad indicated. Refer to line A, Figure 9.
- (.) Cut a 6-1/2 inch length of wire. Strip 1/8th inch of insulation from each end. Connect the other end to the contact indicated on switch S3. Connect the other end to the pad indicated. Refer to line B, Figure 9.
- (.) Cut two 3-1/4 inch lengths of wire. Strip 1/8th inch of insulation from each end. Connect one end of each wire to the contacts indicated on switch S2. Connect the other ends to the pads indicated. Refer to lines C and D, Figure 9.

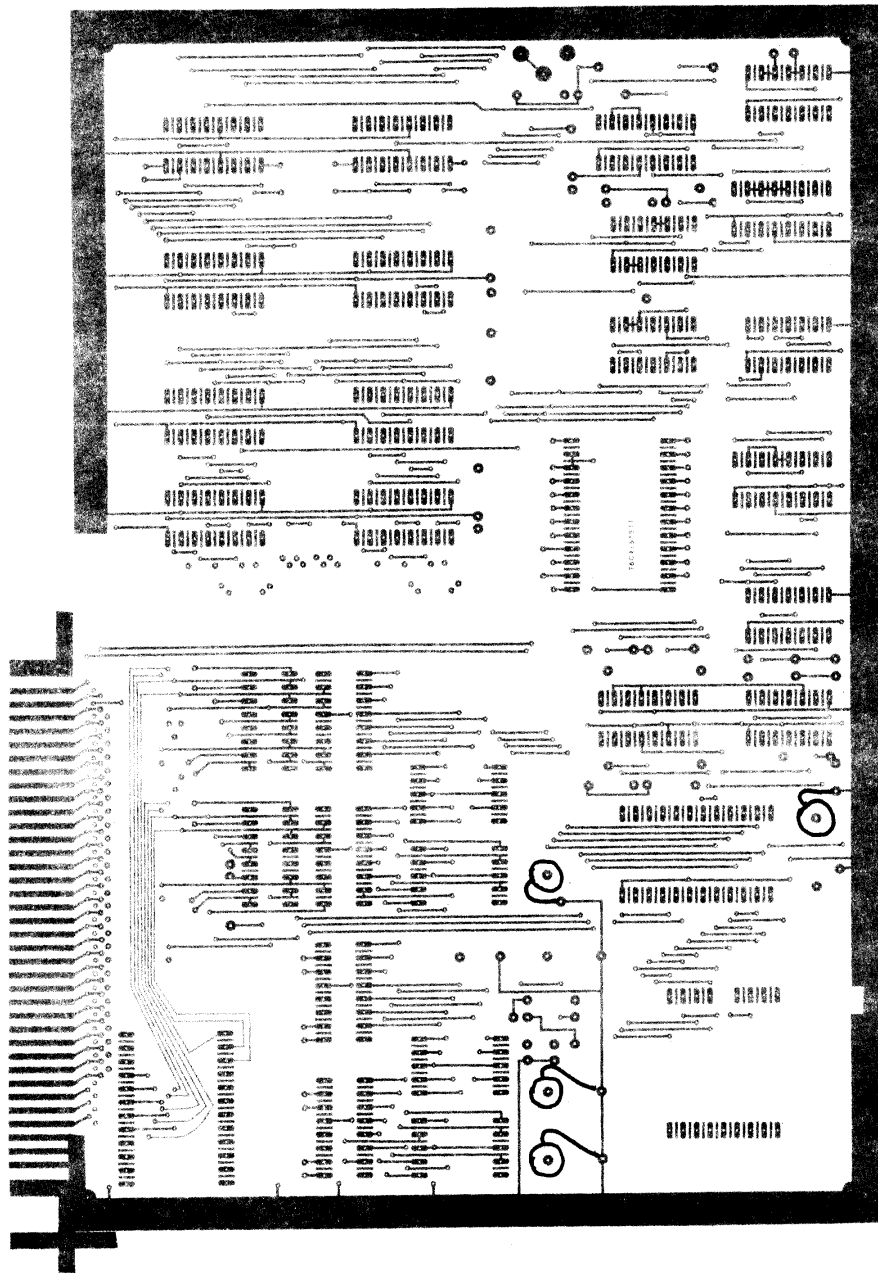

Figure 7. Toggle Switch Locations and Grounding

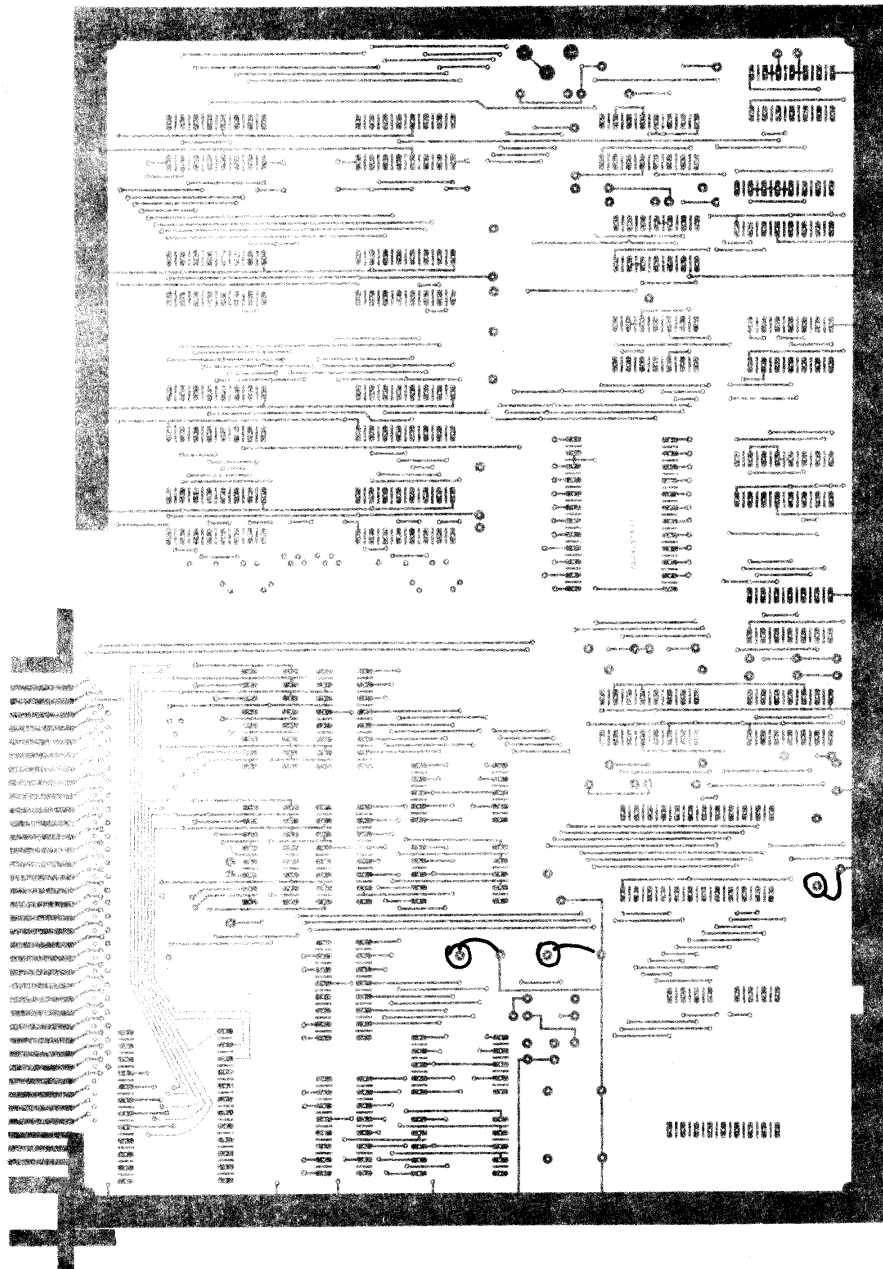

Figure 8. Push Button Switch Locations and Grounding

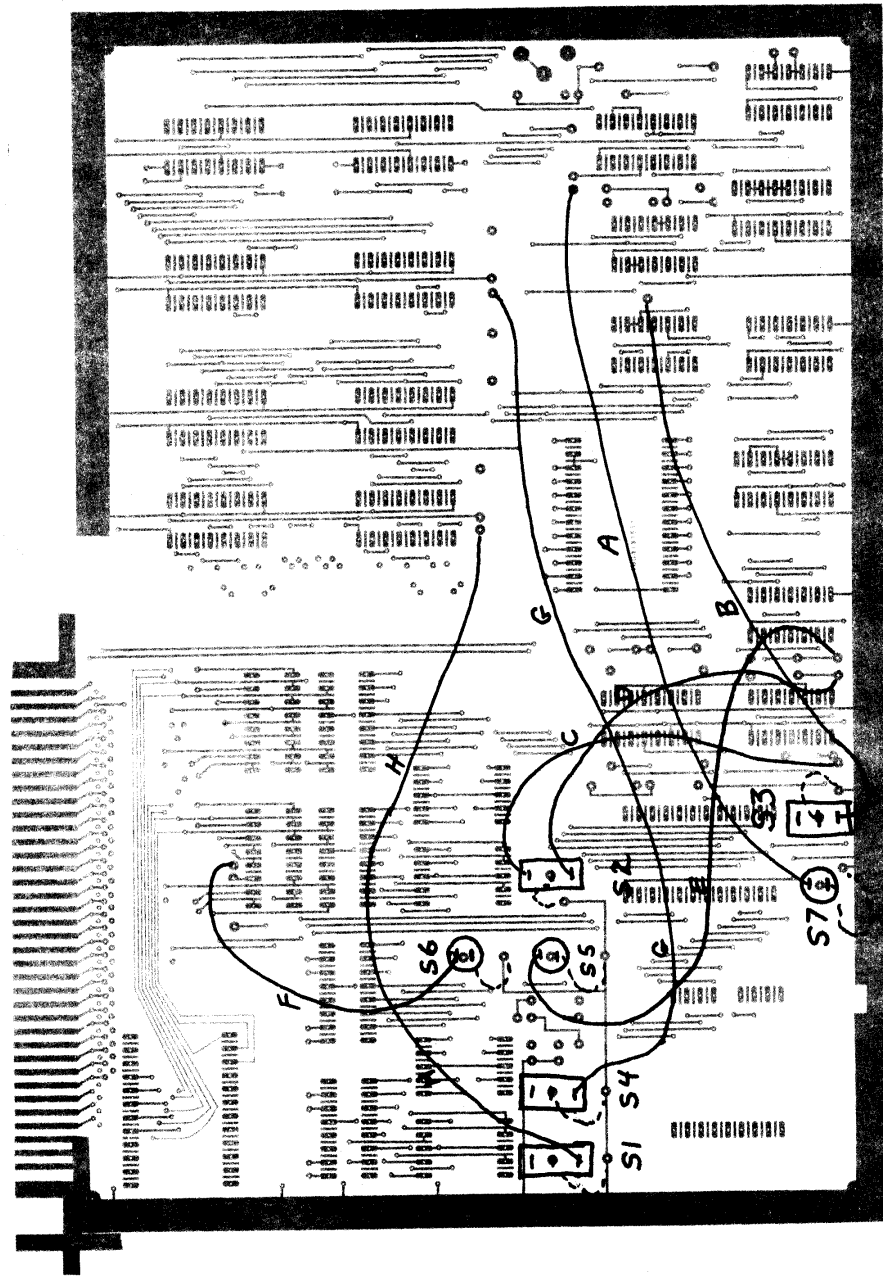

Figure 9. Switch Wiring

- (.) Cut a 3-3/4 inch length of wire. Strip 1/8th inch of insulation from each end. Connect one end to the contact indicated on switch S5. Connect the other end to the pad indicated. Refer to line E, Figure 9.
- (.) Cut a 2-1/2 inch length of wire. Strip 1/8th inch of insulation from each end. Connect one end to the contact indicated on switch S6. Connect the other end to the pad indicated. Refer to line F, Figure 9.
- (.) Cut a 7 inch length of wire. Strip 1/8th inch of insulation from each end. Connect one end to the contact indicated on switch S4. Connect the other end to the pad indicated. Refer to line G, Figure 9.
- (.) Cut a 6 inch length of wire. Strip 1/8th inch of insulation from each end. Connect one end to the contact indicated on switch S1. Connect the other end to the pad indicated. Refer to line H, Figure 9.

Wiring the Bus System

In each of the following steps, prepare the wire lengths indicated by first cutting to length and then stripping 1/8th inch of insulation from each end. Then connect the wires using the figures indicated.

- (.) Cut and prepare eight 7 inch lengths of wire. Connect as indicated in Figure 10.
- (.) Cut and prepare eight 6 inch lengths of wire. Connect as indicated in Figure 11.
- (.) Cut and prepare eight 7 inch lengths of wire. Connect as indicated in Figure 12.
- (.) Cut and prepare eight 7 inch lengths of wire. Connect as indicated in Figure 13.
- (.) Cut and prepare eight 7 inch lengths of wire. Connect as indicated in Figure 14.
- (.) Cut and prepare eight 2 inch lengths of wire. Connect as indicated in Figure 15.
- (.) Cut and prepare eight 7-1/2 inch lengths of wire. Connect as indicated in Figure 16.
- (.) Cut and prepare six 7 inch lengths of wire. Connect as indicated in Figure 17.
- (.) Install and solder all leads on the COPY socket.
- (.) Install and solder all leads on the PROGRAM socket.

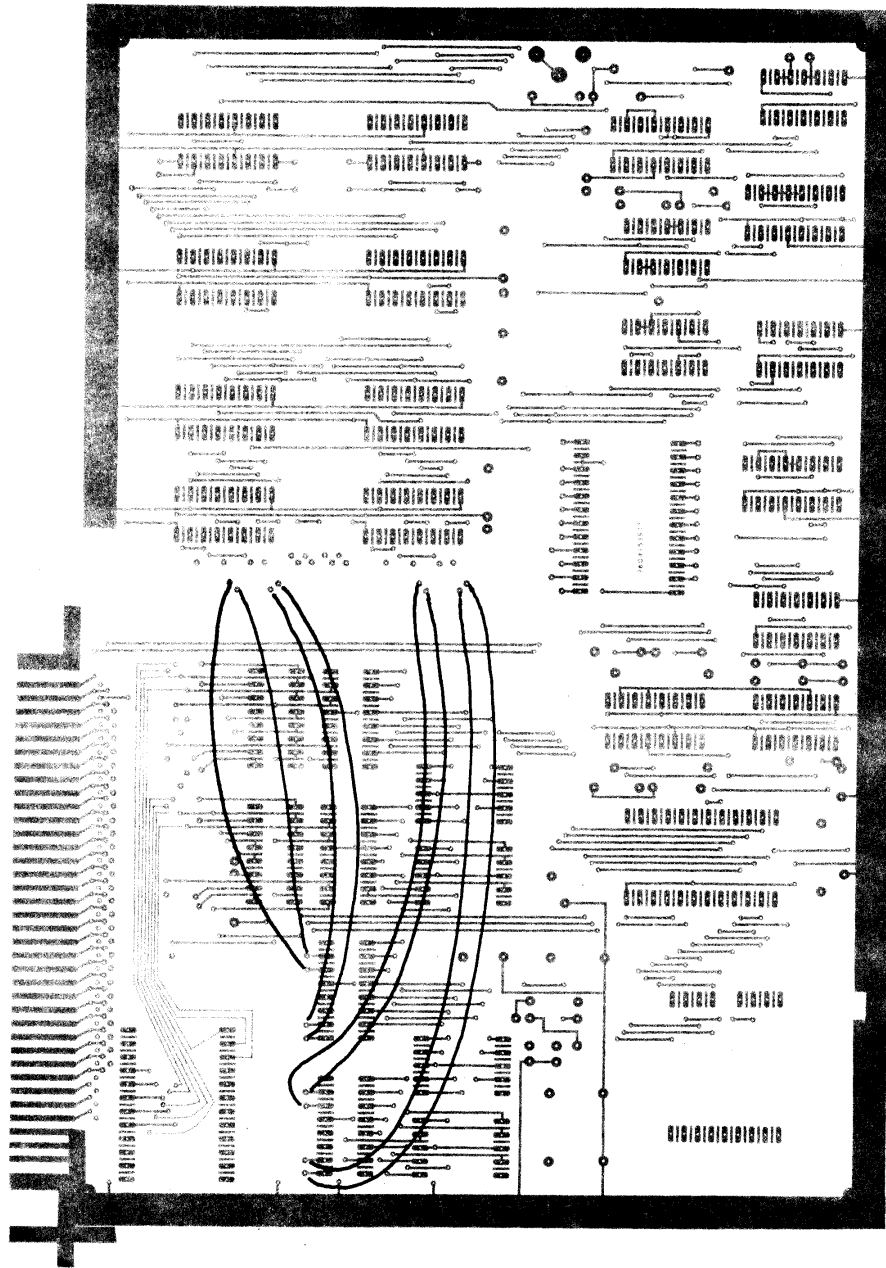

Figure 11. Wiring for Data Display Bus

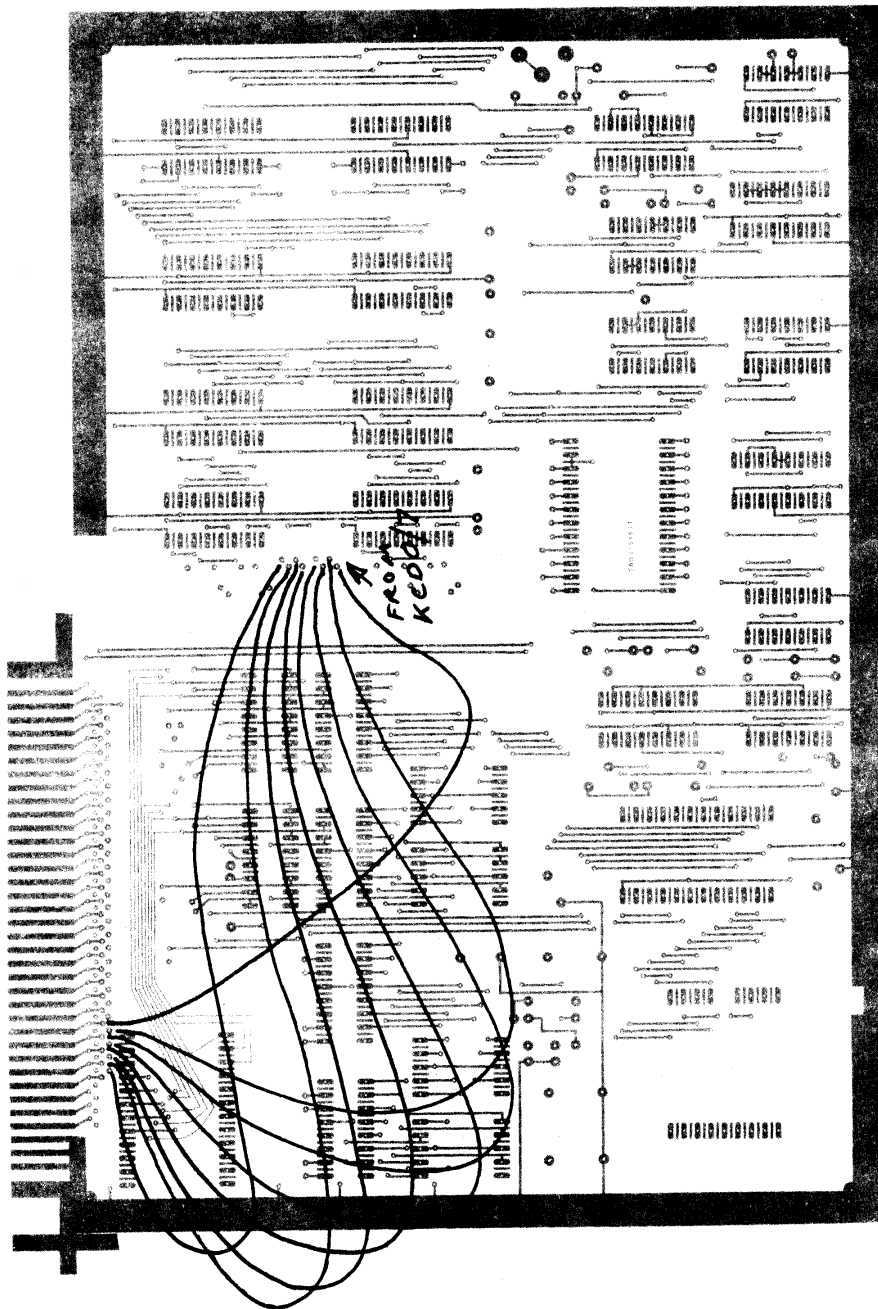

Figure 12. Input to Data Driver Bussing

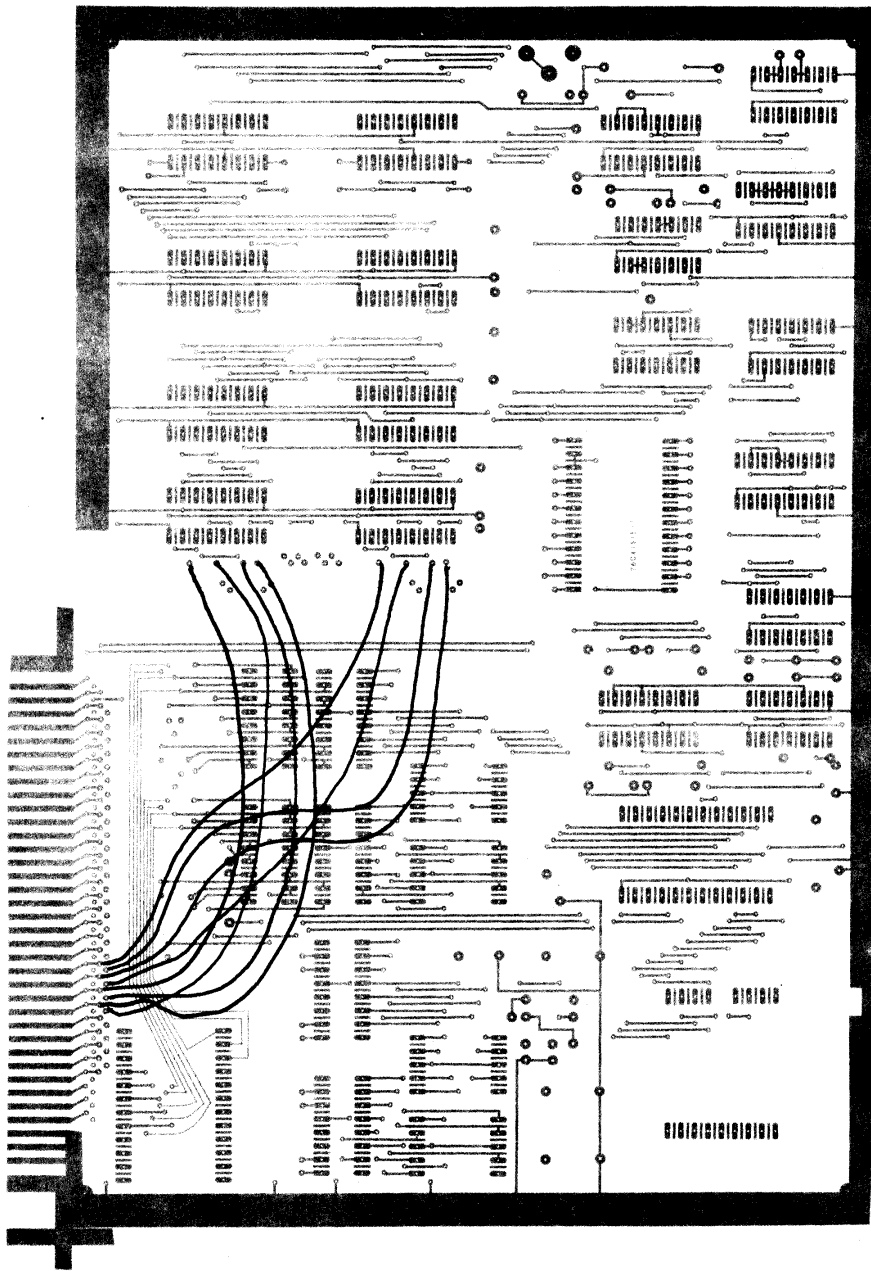

Figure 13. Output from Data Receiver Bussing

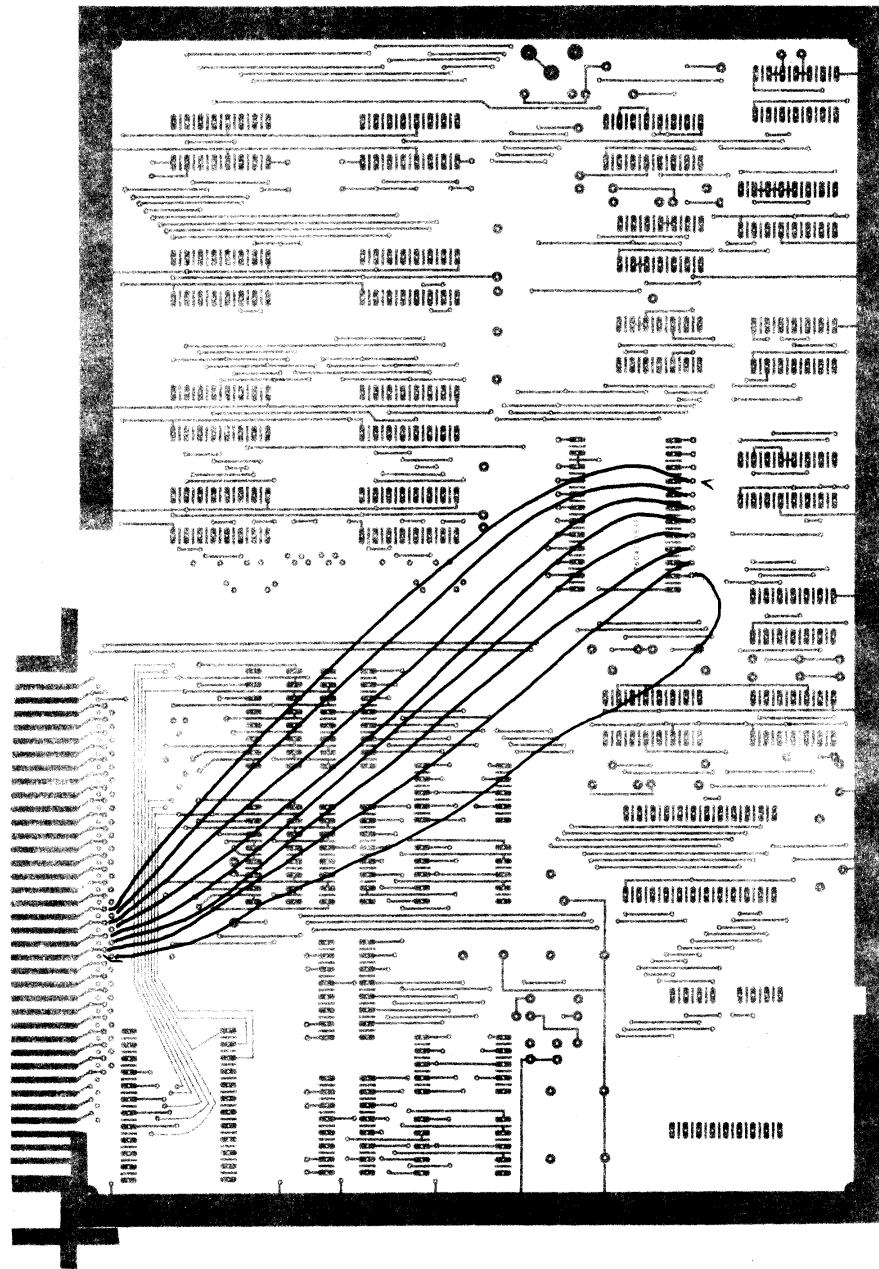

Figure 14. Data Pulse Bussing to PROGRAM Socket

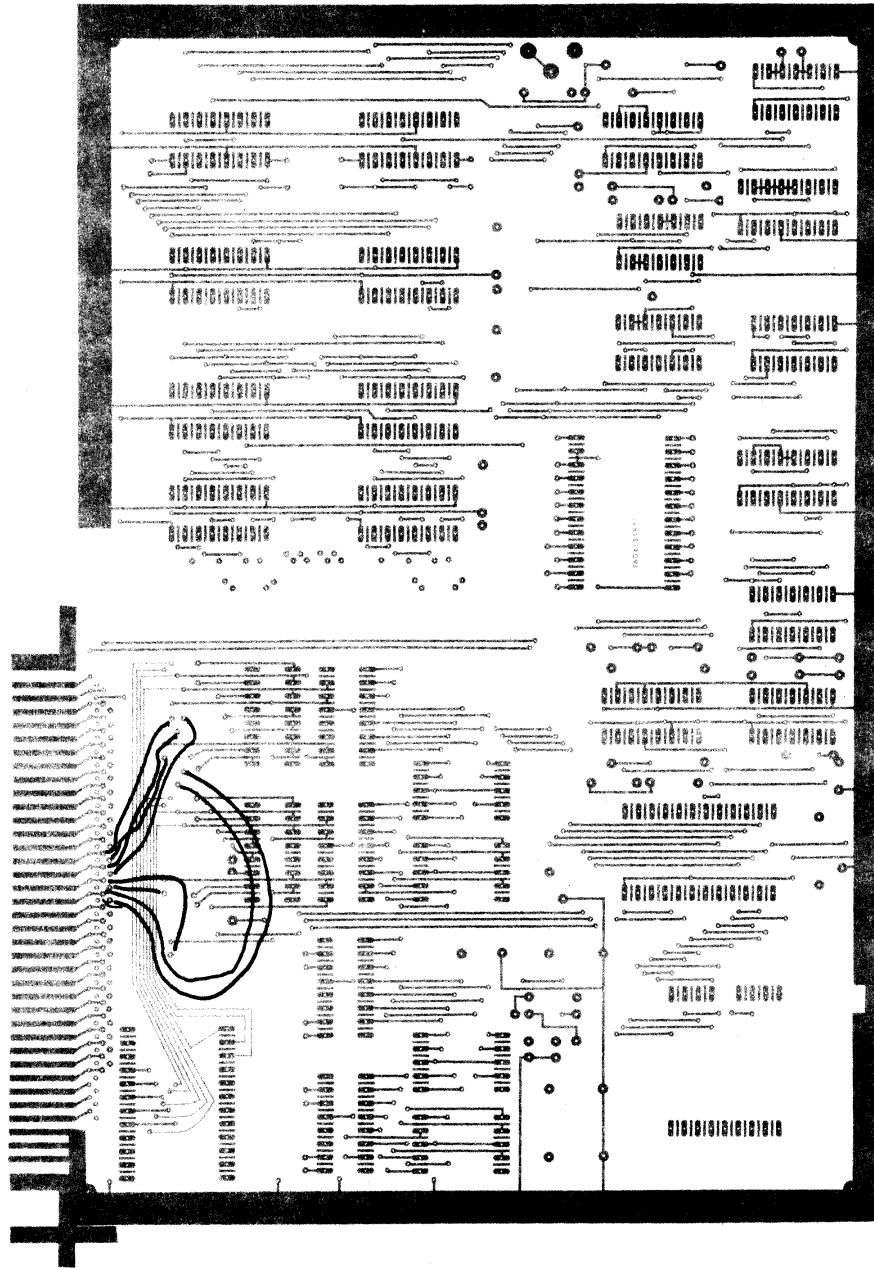

Figure 15. Input to Address Driver Bussing

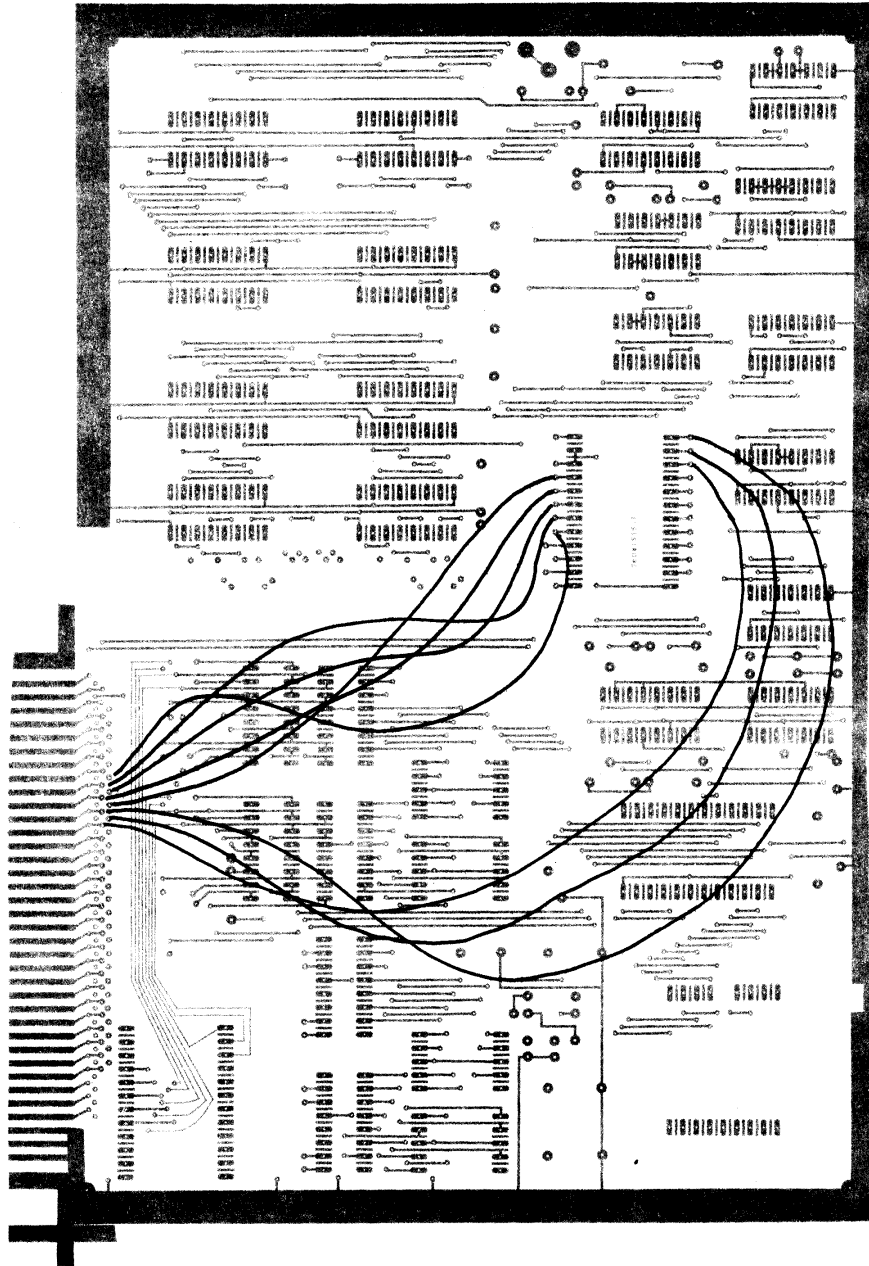

Figure 16. Address Pulses to PROGRAM Socket Bussing

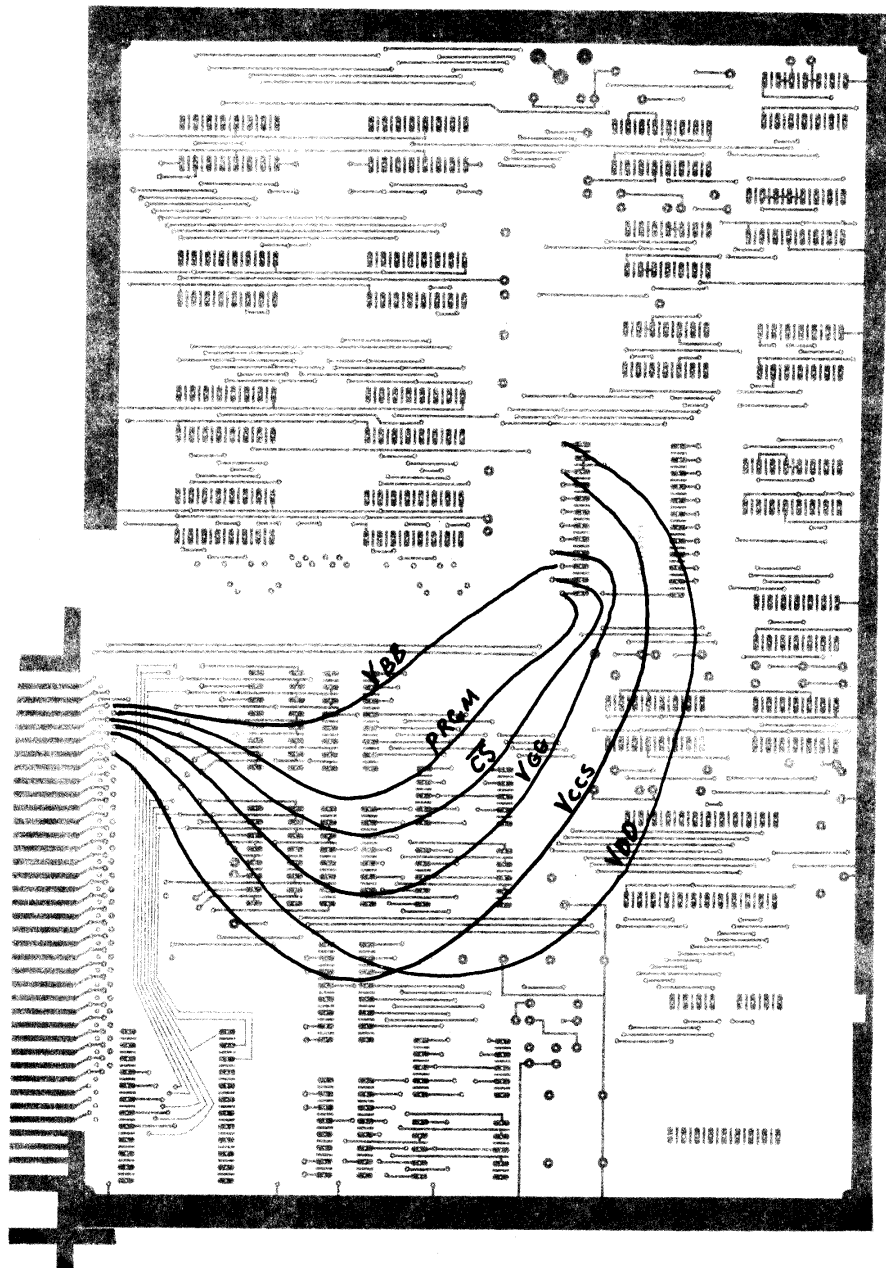
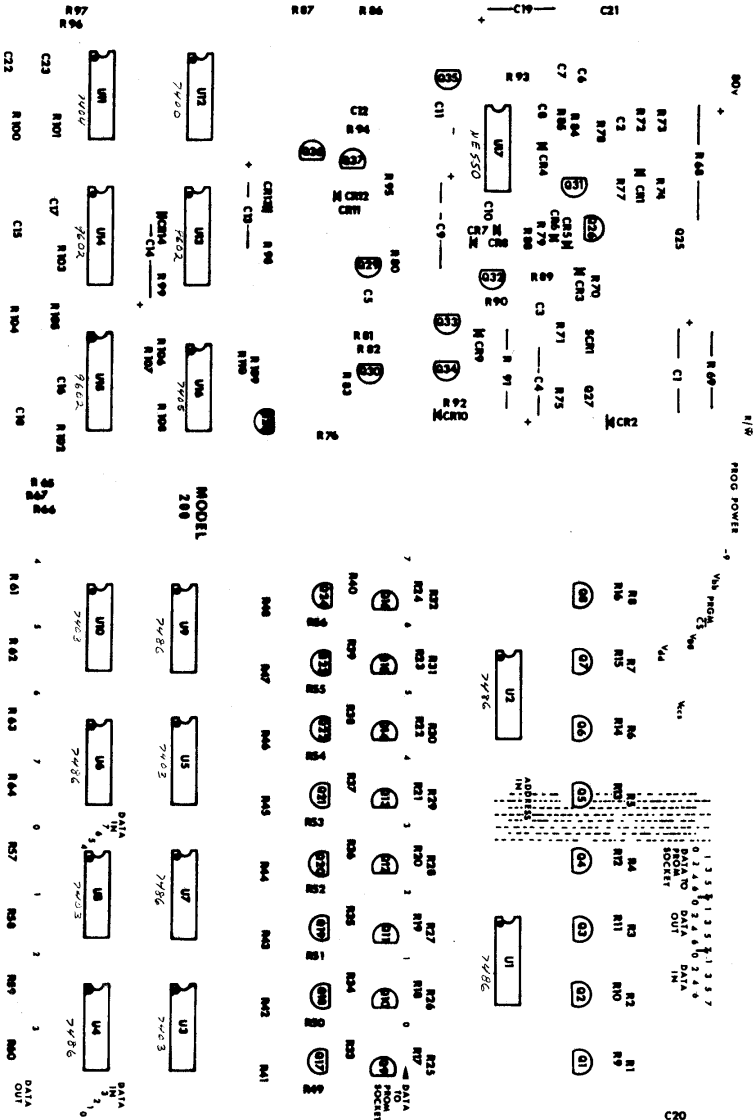

Figure 17. Final PROGRAM Socket Wiring

Installing the Keypad

This completes the assembly of the two cards. Make a thorough visual inspection of all wiring and soldering. Make certain that no solder bridges or other errors exist...particularly in the pulse regulator section and at the edge connectors.

- (c) Each keypad is supplied with two balsa support stringers. These should be applied with something like permabond with one located vertically at either edge of the rubber support pad on the back of the keypad. Locate each one about 1/8th inch from the plastic shell and parallel with the connectors. The holes for the connector pins on the data entry card have been made snug intentionally. Careful alignment and gentle pressure will start the connector assembly through the holes. Do not force or distort the pins. Use just enough heat when soldering to make a good connection. Excess heat can, but probably won't, damage the keypad.



PROFILE CARD PARTS LIST

Integrated Circuits

U12	7400
U3, U5, U8, U10	7403
U11	7404
U16	7405
U1, U2, U4, U6, U7, U9	7486
U13, U14, U15	9602
U17	NE550

Ceramic Capacitors

C8	100 pF
C2, C5, C10	200 pF
C7, C11, C22, C23	.001 mF
C3	.01 mF
C6	.05 mF
C12, C20, C21	.1 mF

Mylar Capacitors

C17	.02 mF
C16	.05 mF
C15, C18	1.0 mF

Electrolytic Capacitors

C13	2.2 mF, 16 V
C4, C19	5 mF, 16 V
C1, C9	5 mF, 50 V
C14	22 mF, 16 V

Resistors (1/4 Watt)

R84	22
R17-R24, R89	100
R76	220
R9-R16, R82	330
R74	390
R70, R90, R108	470
R33-R48, R71, R75, R94, R95	1 K
R80, R81, R83, R85, R92, R101, R105, R109, R110	4.7 K
R57-R67, R96, R97	5.6 K
R1-R8, R25-R32, R49-R56	6.8 K
R73, R77, R79, R86, R88, R103	10 K
R102	12 K
R98, R99	20 K
R93, R106, R107	27 K
R72	33 K
R78	100 K

Resistors (1, 2, and 5 Watts)

R91	8.2 K, 1 watt
R69	0.5 ohm, 2 watt
R68	5 ohm, 5 watt

Resistors (Trimmer)

R87	10 K
R100, R104	20 K

Transistors

Q1-Q24, Q26, Q28, Q29, Q31-Q35, Q37	PE6021
Q25	MJE6045
Q27	2N4920
Q30, Q36	PE2907

Diodes

CR1, Cr11	1N5258 (36 volt zener)
CR2	1N4002 or equal
CR3	1N5263 (56 volt zener)
CR4	1N5242 (12 volt zener)
CR5, CR6, CR8, CR10, CR12, CR13, CR14	1N914 or equal
CR7	1N5264 (60 volt zener)
CR9	1N5231 (5.1 volt zener)

Thyristors

SCR1	MCR106-4
------	----------

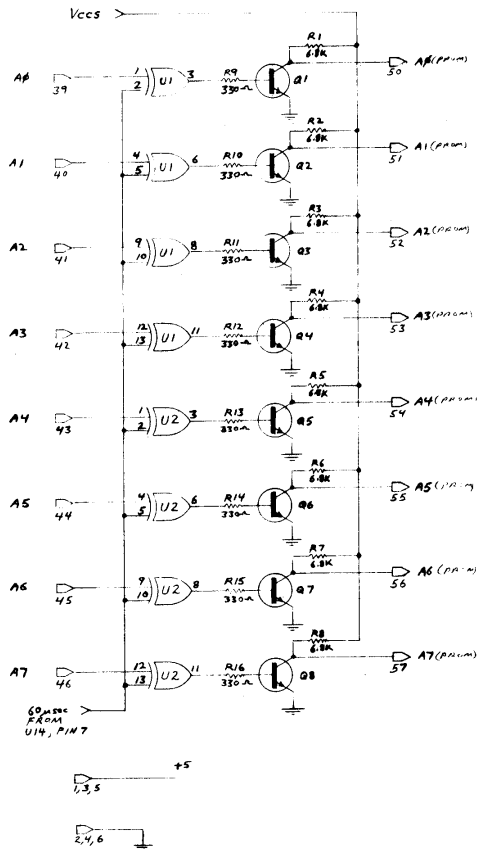

ADDRESS DRIVERS
 Profile Card
 1 of 3

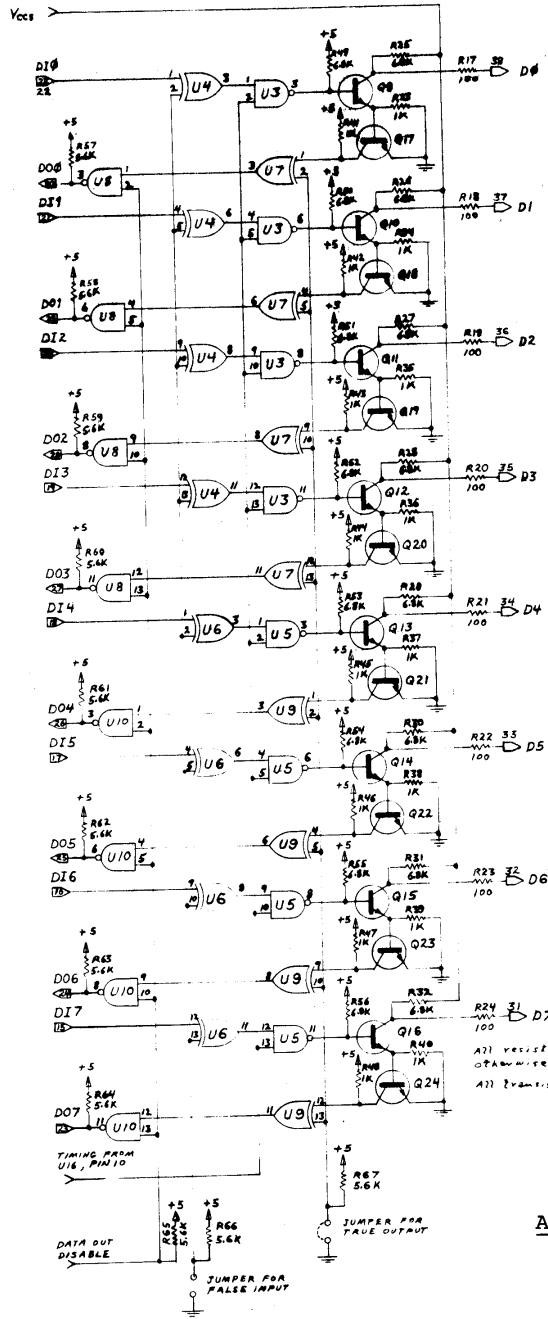

Outputs this side are DATA to PROGRAMMING SOCKET

All resistance values are in ohms unless otherwise stated.
All transistors are PE 6021 or equivalent

**DATA DRIVERS
AND RECEIVERS**
Profile Card
2 of 3

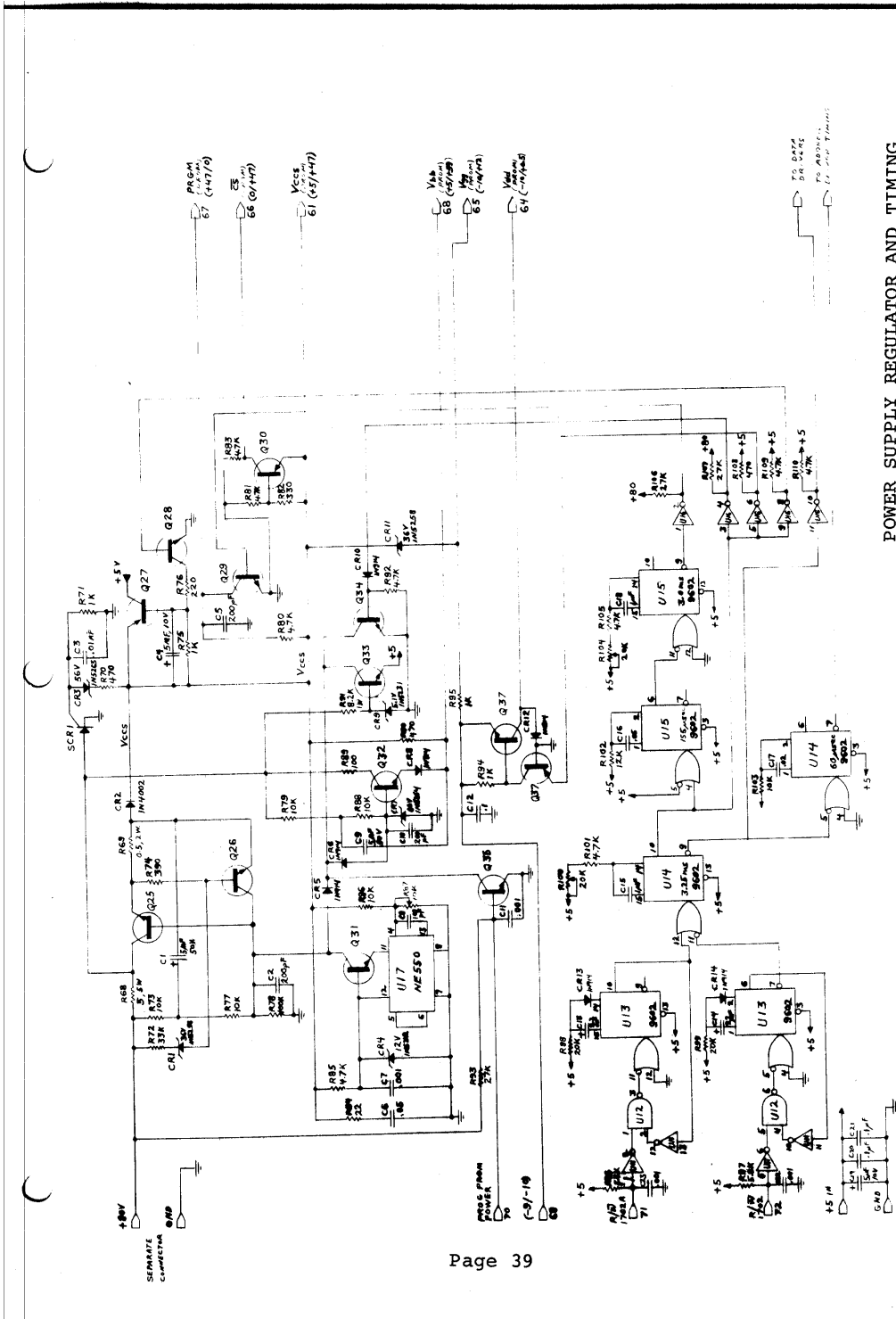

POWER SUPPLY REGULATOR AND TIMING
Profile Card
3 of 3

DATA ENTRY CARD PARTS LIST

Integrated Circuits

U5, U15, U19	7400
U1	7404
U6	7410
U9, U10	7475
U2, U4	7476
U16, U17	7485
U7	7493
U8	74154
U11, U12, U20, U21	74157
U13, U14	74193
U22, U23, U24, U25	9368
U3, U18	9602

Capacitors (Ceramic)

C1	.01 mF
----	--------

Capacitors (Electrolytic)

C2, C3, C4	10 mF, 16 V
C5	50 mF, 16 V

Resistors (1/4 Watt)

R8, R13	470
R2, R4, R5, R6, R7, R9, R14, R15	1 K
R11	4.7 K
R1, R10	10 K
R3	47 K

Resistors (Trimmer)

R12	50 K
-----	------

Light Emitting Diodes

LED1, LED2	1/8 inch red LEDs
DISP1, DISP2, DISP3, DISP4	FND500 seven segment display

Switches

S1, S2, S3, S4	SPDT toggle switch
S5, S6, S7	SPST push button switch

Diodes

CR1, CR2, CR3, CR4

1N914

Miscellaneous

Printed Circuit Board
Wire, Miscellaneous Hardware
Hex Keypad (KP1)

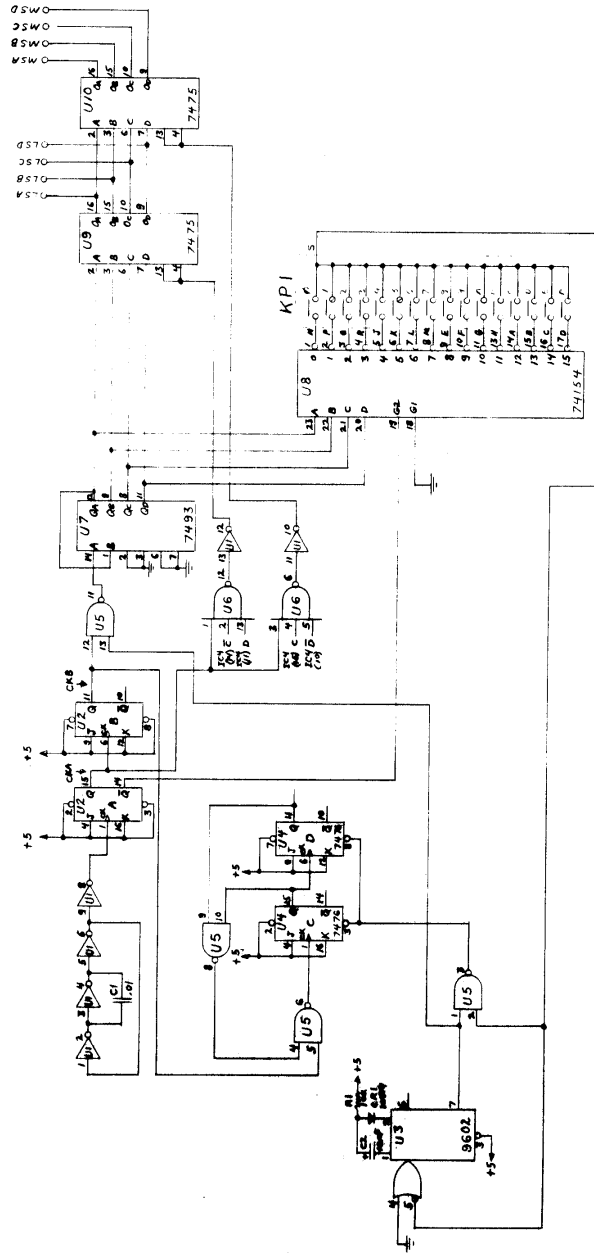

**KEYPAD ENCODING LOGIC
AND DATA LATCH**
Data Entry Card
1 of 3

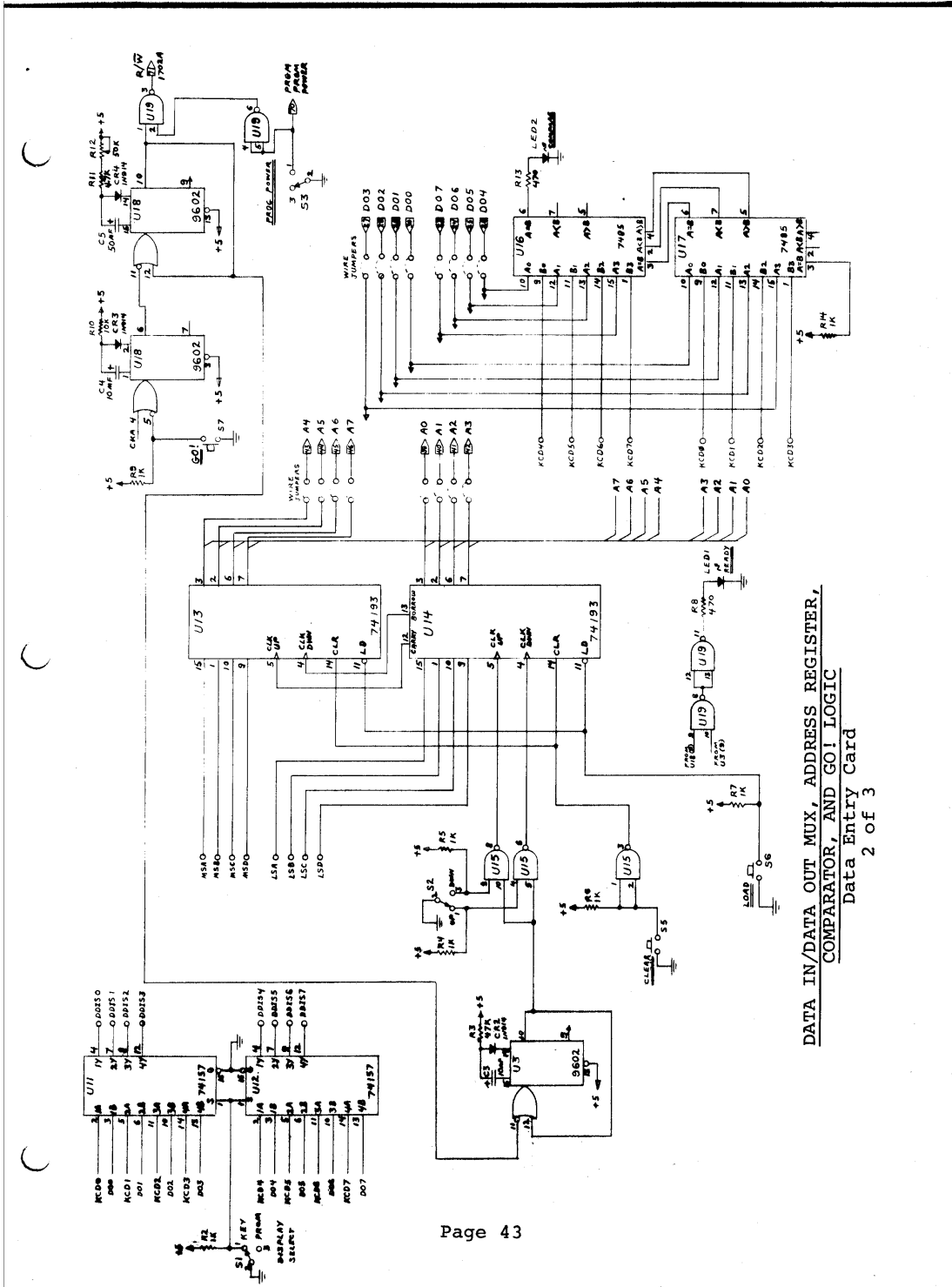

DATA IN/DATA OUT MUX, ADDRESS REGISTER,
COMPARATOR, AND GO! LOGIC
Data Entry Card
2 of 3

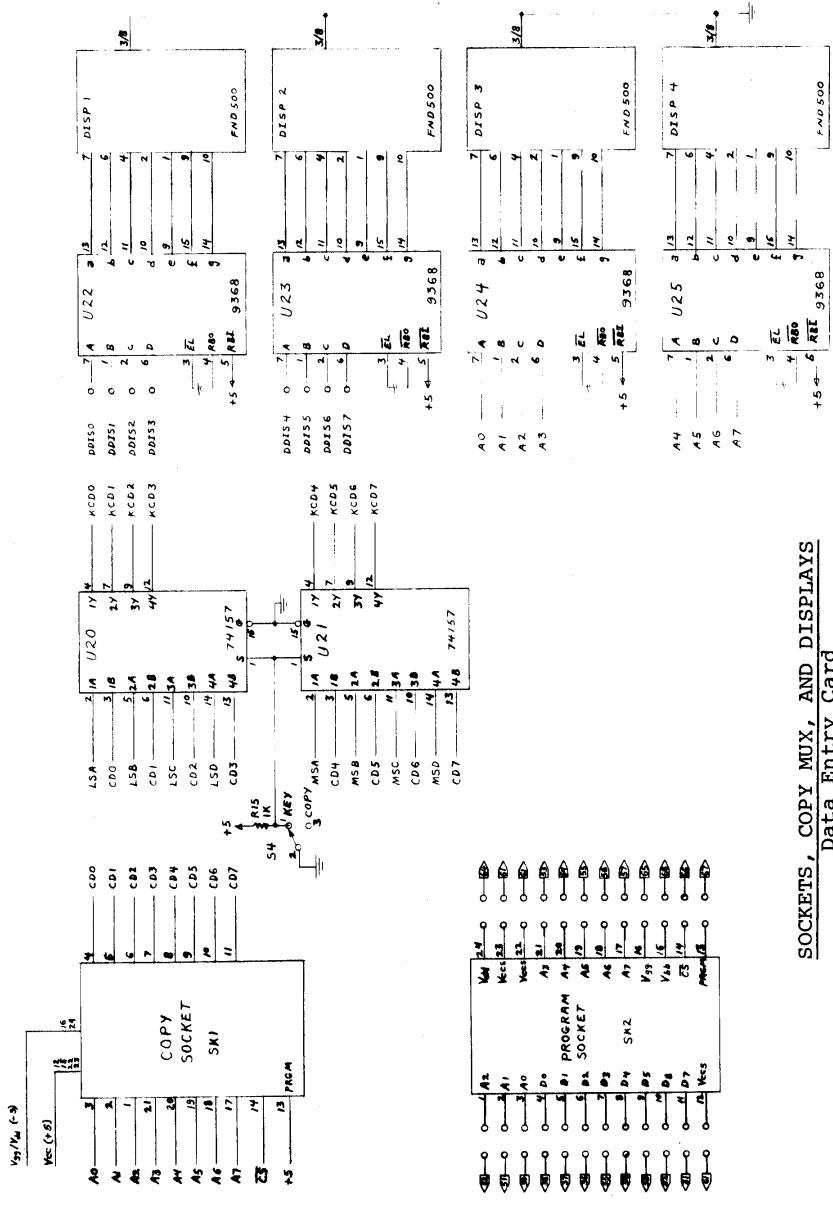

SOCKETS, COPY MUX, AND DISPLAYS
Data Entry Card
3 of 3

KC00 through KC07 and to 00 through D7

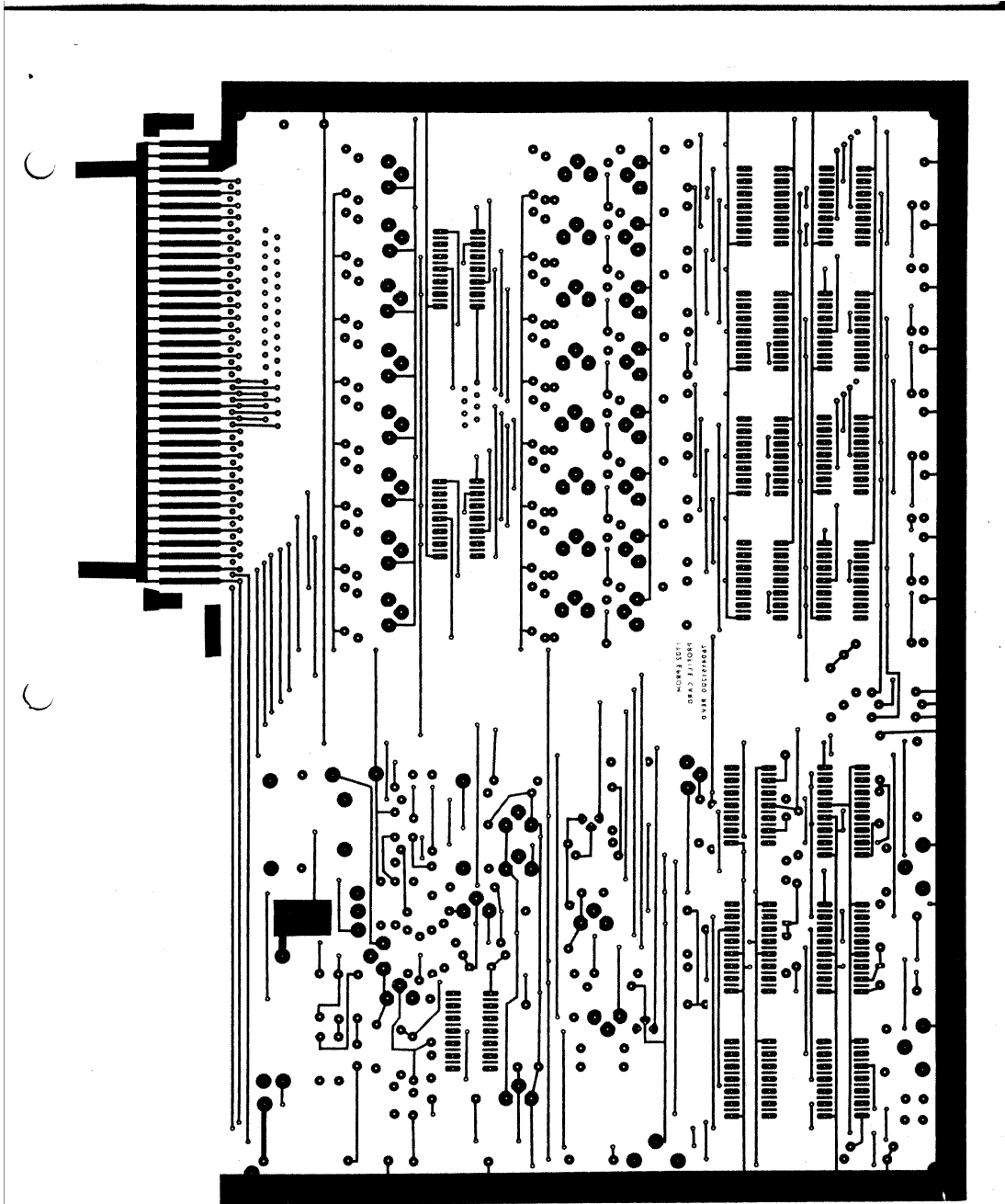

NO. 1001
DATE 1/1/68
BY J. K. [unreadable]

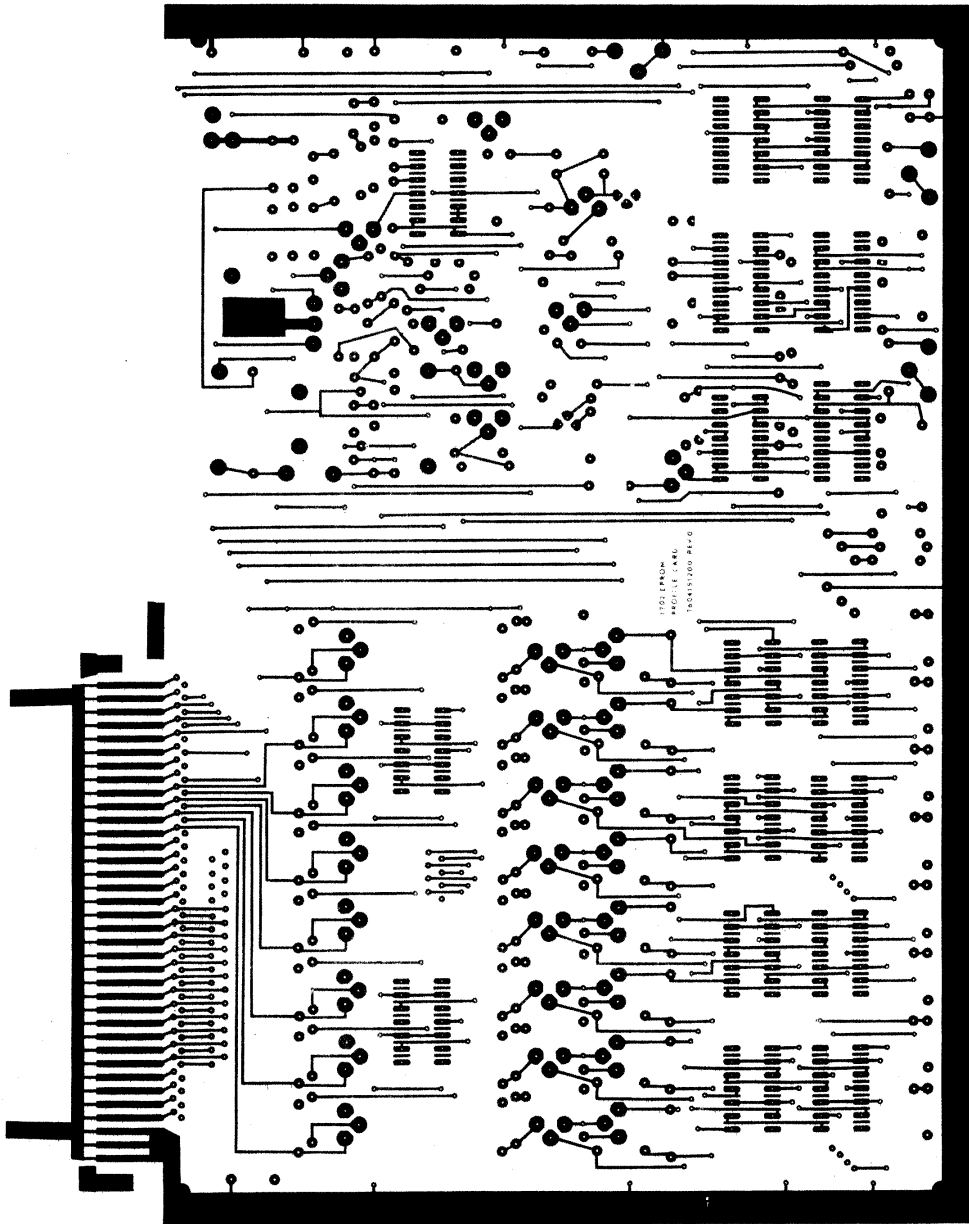

1001 EPSON
MODEL 1440
10011000 0410

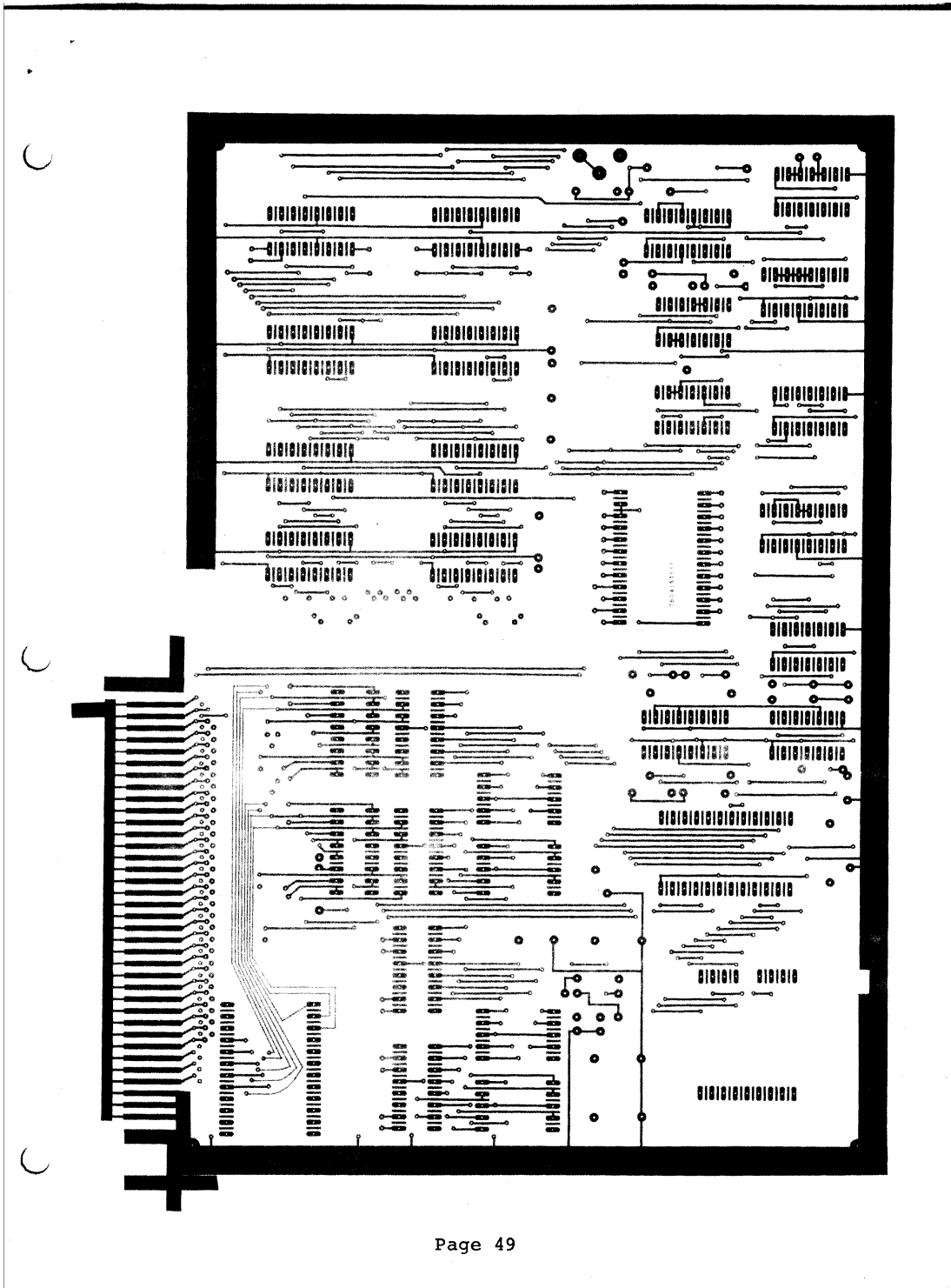

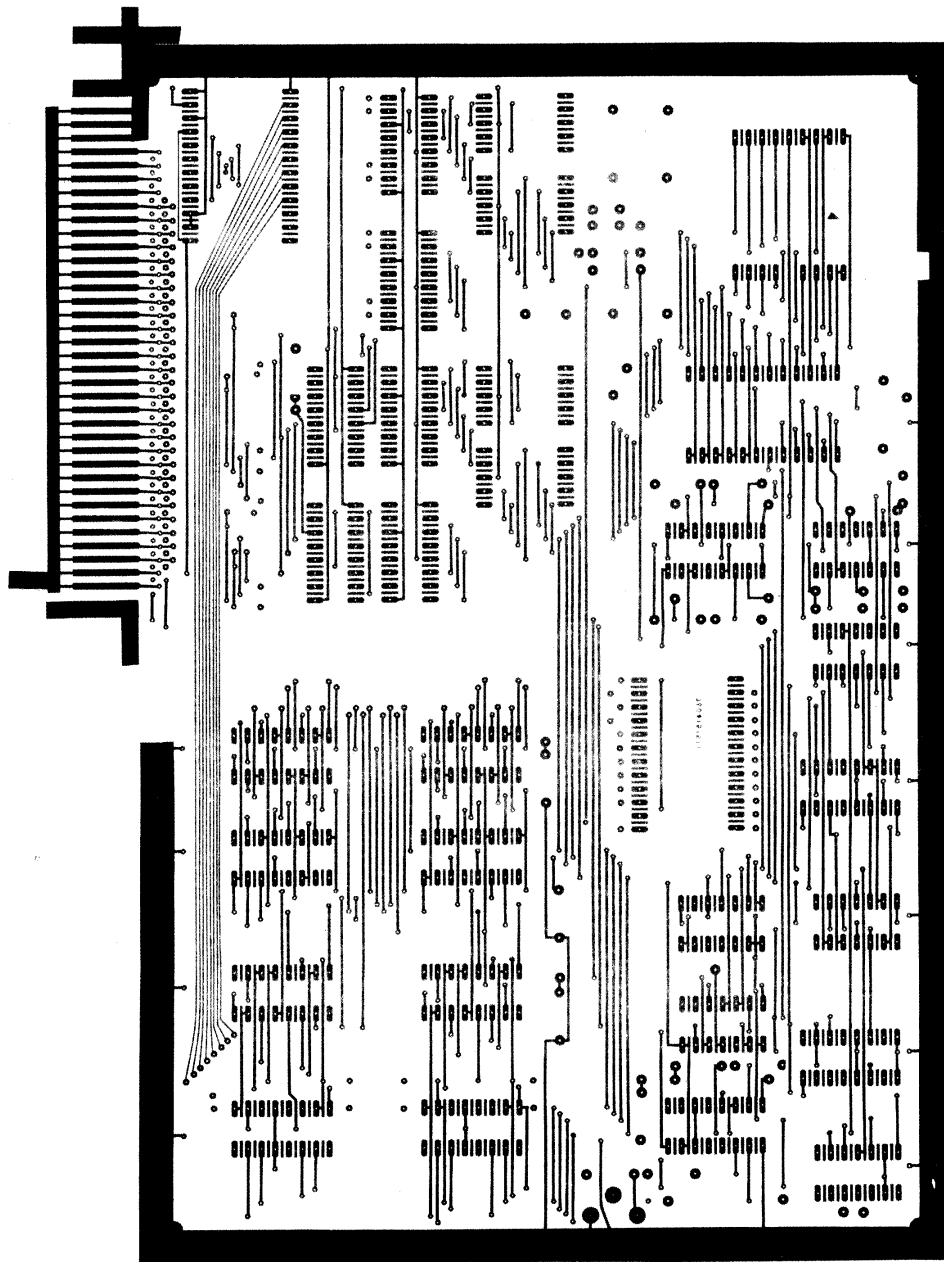

ACCESSORIES AND SPECIALS

1702 EPROM PROGRAMMER INTERFACE

Circuitry and software listings are supplied free-of-charge with the EPROM PROGRAMMER. The basic interface connections are shown below.

All lines are TTL compatible and can be driven or read using TTL compatible INPUT and OUTPUT PORTS. TWO

8-bit output ports are required for DATA TO PROGRAMMER and ADDRESS. One 8-bit input port is required for VERIFICATION DATA. One status line is required to sample the R/W line. One control line is required to drive the GO! circuitry.

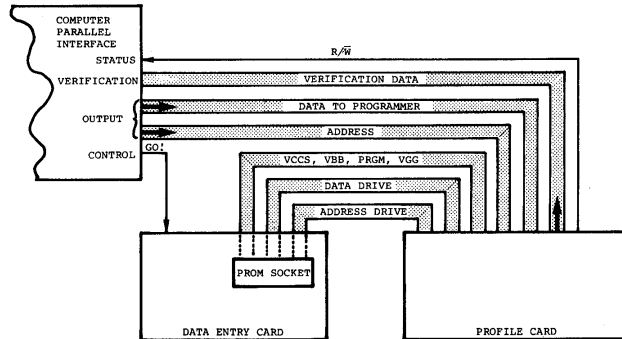

POWER SUPPLY

A separate, open-chassis power supply is available for the EPROM Programmer. The Power supply includes +5 Volts at 2 Amps; -9 Volts at 100 milliamps; and +80 Volts at 400 milliamps. The price complete, assembled and tested but without power card is \$69.95.

BRIEFCASE UNIT

We will build the programmer, power supply and DB-25 interface connectors into a briefcase with a front panel, power cord, and switches.

The displays, keypad, controls, and socks are also brought up to and installed on the front panel. These units are built up as required and may take from 2 to 4 weeks for delivery. The price complete is \$599.95.

Associated Electronics Company
P.O. Box 1720A
12444 Lambert Circle
Garden Grove, CA 92641

